



Laser Tools & Technics Corp.

User Manual

Version 1.2 e

V2000 Series

Copyright in this manual is owned by LTT, Inc. 2018

D022000100

Introduction

Technical Support

Thank you for purchasing the V2000series. This product is warranted to be free of manufacturing defects for one year from the date of purchase. If you cannot find the solution to your particular application, or/if for any reason you need additional technical assistance. Our technical support group is glad to work with you in answering your questions, please use the ways as following:

Tel: 886-3-5727772 (Mon.-Fri., 8:30- 18:00, Taiwan)

Fax: 886-3-5728898

Email: service@littcorp.com

Web: www.littcorp.com

Address: No. 121, Lane 99, Pu-Ding Road, Hsin Chu City, Taiwan, R.O.C.

Disclaimer

The information provided in this document is believed to be reliable. However, no responsibility is assumed for any possible inaccuracies or omissions. Specifications are subject to change without notice. The Windows XP/Windows 7/Windows 8 are registered trademarks of Microsoft. Other trademarks are the property of their respective owners.

LTT reserves the right to make changes without further notice to any products herein to improve reliability, function, or design. LTT does not assume any liability arising out of the application or use of any product or circuit described herein; neither does it convey any license under its patent rights, nor the rights of others.

Special Symbols



Failure to follow instructions may lead to product damage, or error.



Failure to follow instructions may lead to injury byelectric shock.



Failure to follow instructions may lead to injury byinvisibleradiation.

Contents

Introduction	1
Technical Support.....	1
Disclaimer	1
Special Symbols.....	1
Chapter 1 Safety	4
1.1 Safety Regulation.....	4
1.2 Name Plate and Warning Labels	6
1.3 Safety Protection Device	8
Chapter 2 Installation.....	10
2.1 Unpack and Locate Machine.....	10
2.2 Package Contents List.....	13
2.3 Part Names and Functions	14
2.4 Hardware Installation.....	20
2.5 Driver Installation.....	22
2.5.1 Uninstall Driver.....	22
2.5.2 Uninstall Driver.....	28
2.5.3 Change USB Cable to Another Port.....	31
2.6 CorelDRAW Setup.....	33
2.7 AutoCAD Setup.....	37
2.8 LTT Product Tools.....	45
2.8.1 Install Procedure.....	46
2.8.2 Uninstall Procedure.....	50
Chapter 3 Operation	52
3.1 Operator Position	52
3.2 Basic Operation Flow.....	53
3.3 Machine Operation	54
3.3.1 Control Panel.....	54
3.3.2 Operating Menu.....	57
3.4 Print Driver Operation.....	64
3.4.1 Laser Tab.....	64
3.4.2 Job Tab	錯誤! 尚未定義書籤。
3.4.3 Page Tab.....	71
3.4.4 Power Scale.....	73
3.5 LTT Product Tools.....	74
3.5.1 System Upgrade.....	74
Chapter 4 Maintenance.....	76
4.1 Cleaning	76
Chapter 5 Trouble Shooting	79

Appendices	80
Appendix 1 Specifications	80
Appendix 2 Dimensions.....	81
Appendix 3Suggested Power and Speed Settings	82

Chapter 1 Safety

1.1 Safety Regulation



The V2000 series uses a CO₂ Laser as a light source. It is classified as a class-IIIR product by **CDRH**(the **Center for Devices and Radiological Health**).



Wavelength : 10.6 μ m

Maximum output power : 30 W

Visibility : Invisible



When operating the V2000 series, be sure to always comply with the safety regulations as following:

- Do not attempt to modify or disassemble any component of the machine without LTTtechnical support.
- Do not open the doors of chassis and access the laser tube or electronic components, especially while the machine power is on.
- Connect the machine to a grounded outlet. Verify that the voltage of the outlet is correct for the machine.
- Do not disable the interlocks which are on acrylic lid.
- Be careful about the path of the invisible laser beam shown in figure. Otherwise, eye or skin injury may result.

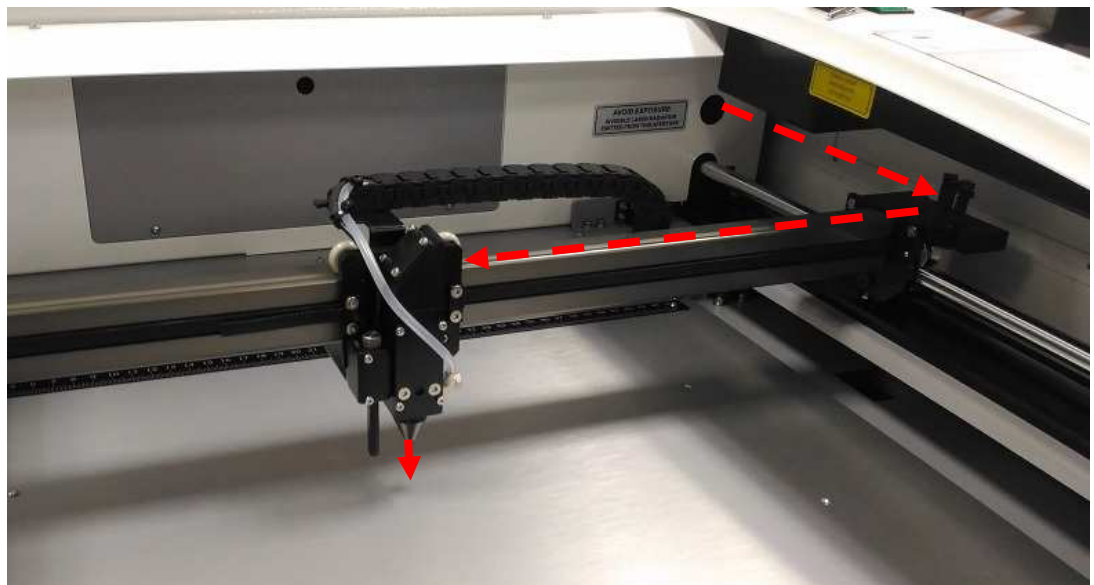

Chapter 1 Safety

- Do not watch the laser beam directly during operation. Bright light caused by the lasing process can damage the eye.
- The side and front doors are fixed by screws for safety. If you open these doors, the V2000 will become a Class 4 laser device. For your safe, please wear protective goggles.
- The laser beam may cause fire. Never leave machine alone without operator watching during the laser cutting and engraving process. Keep a fire extinguisher near the machine at all times.
- Blowing materials with air flow from nozzle while cutting or engraving can avoid fire occurring and also obtain good quality.
- Verify that materials used in the engraver are proper for lasing. Never engrave or cut substrates that contain **PVC** or **Teflon**.
- Good efficiency of exhaust system makes you avoid breathing dust, debris or poison gas.
- Please comply with maintenance schedule as chapter 4 to keep V2000 working well.
- Before you execute auto focusing function, please make sure that there will be no crashing between motion system and other objects. For safety, it is **NOT** recommended to use auto focusing function on inequality materials.

1.2 Name Plate and Warning Labels

The labels as following are affixed to the V2000. These labels must never be removed. If they are damaged or tampered for any reason, please request for LTT immediately to replace them.

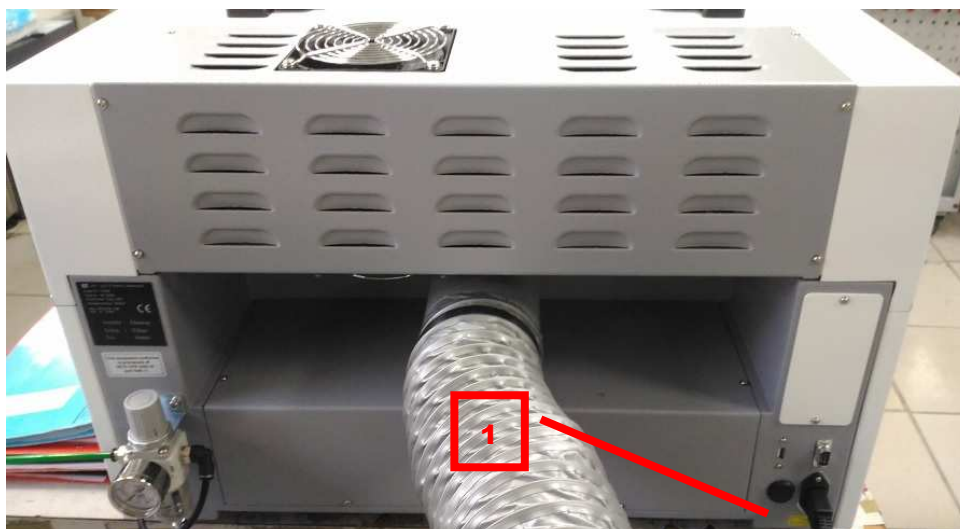

1



2



1.3 Safety Protection Device

■ Interlock

The laser beam will not be emitted if you open the **acrylic lid**. When the acrylic lid is opened, the LED indicator of "**DOOR**" on control panel will be off.

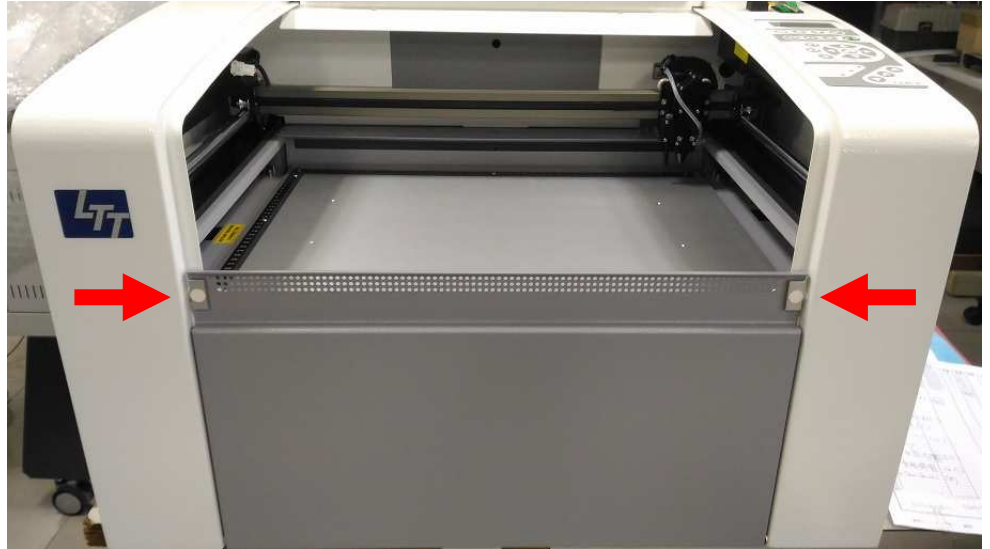

Door close



Door open

■ Laser Switch

Laser switch can shut down the power of lasertube immediately, and it has no effect on motion system. Compared with interlock, turning off laser switch can save power. When you turn on laser switch, the LED indicator of "**LASER**" on control panel will be on (it needs to take more than 5 seconds to warm up laser tube while you turn it on).



■ ON



LASER 

■ OFF



LASER 

Chapter 2 Installation

2.1 Unpack and Locate Machine

This section explains how to unpack and locate machine.

1. Remove the strings.



2. Remove the protective bag.



3. Remove the top cover.



4. Remove the side cover and foam.



5. Remove the protective bag.



6. Locate the machine and keep the recommended space for maintenance.

Unit: mm

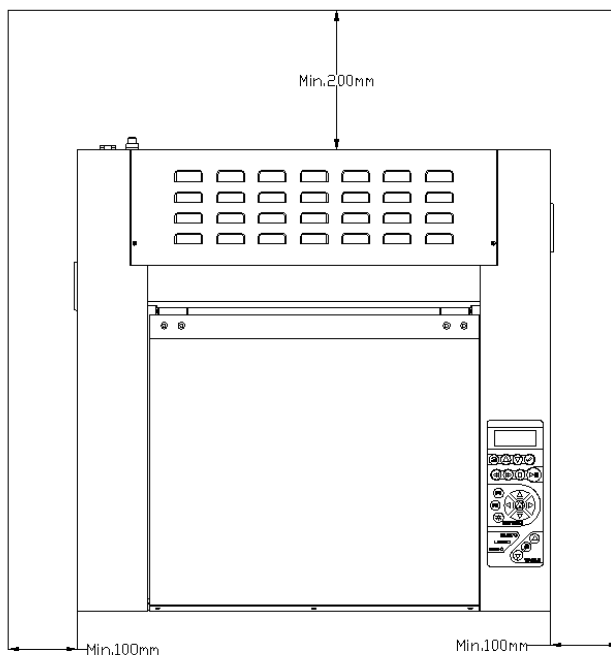

2.2 Package Contents List

This section explains the package contents of the V2000. The packages include the following components. Before using the unit, check that all components have been included in the packages.



- | | |
|--------------------------|----------------------------------|
| 1 Box | 5 Printer Driver CD-Rom |
| 2 Cotton Swab | 6 USB Cable Driver CD-Rom |
| 3 Alcohol Dropper | 7 USB Cable |
| 4 Allen Wrench | 8 Power Cable |

2.3 Part Names and Functions

This section explains the main part names and functions of the V2000.

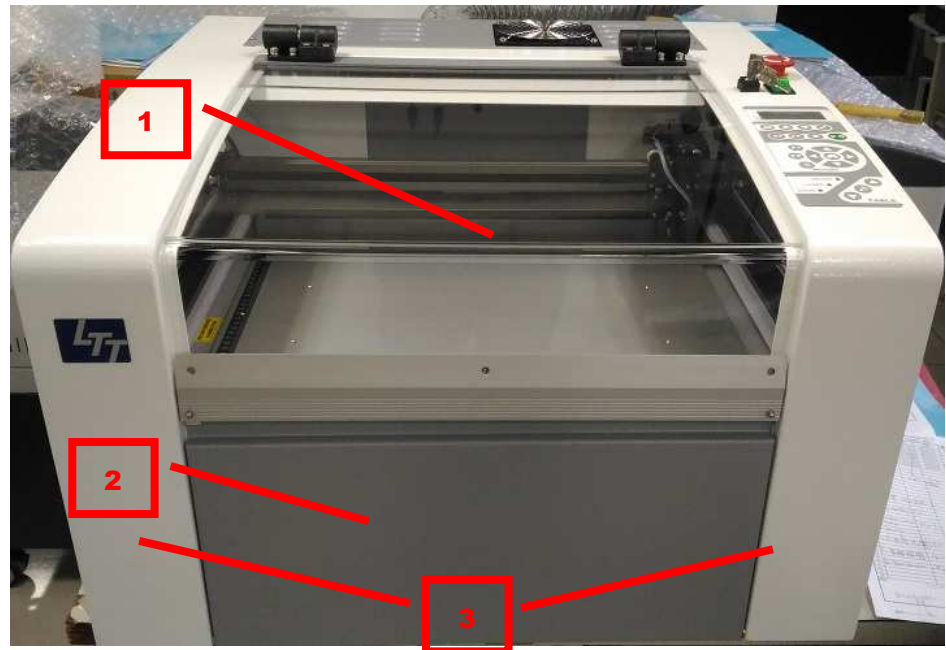

1. Acrylic Lid

This lid has interlock sensors for safety. If you open this door, the laser will be not emitted.

2. Front Door

This door is locked by screws for safety.



3. Side Door

You can work on long materials through two side doors. These doors have no interlock sensors, so they are locked by screws for safety. If you open these doors, the system becomes a Class 4 laser device.

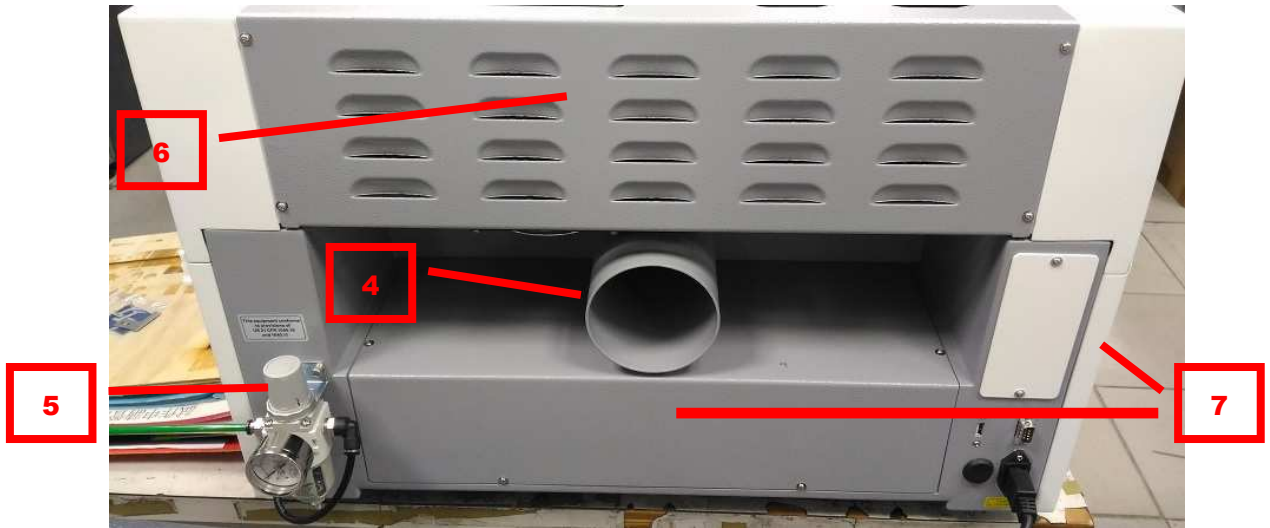

4. Exhaust Port

The port can exhaust the smoke which is caused by cutting or engraving. These ports have to be connected to blower through pipes

5. Air Filter

This part provides air assist through the hose which is connected to air compressor.

6. Laser protective cover and Fans

This part can dissipate the heat in the chassis which is caused by laser tube.

*The fans are only available on Vi30 laser model.

7. Back Side Door (Left) and Electrical box cover

The switching power supplies for this machine are mounted in this electrical box. Some other electrical components are at inside of the back side door (left).



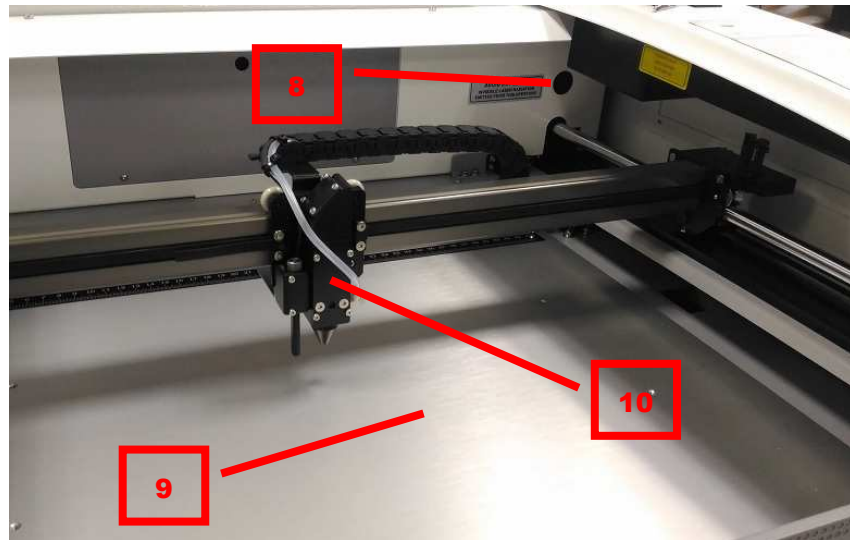

8. Window Lens

This part can protect 1st mirror against dusts or debris. It should be cleaned this lens daily. (See [chapter 4](#))

9. Table

This part can carry materials for cutting and engraving. You can move it up and down by the keys on control panel. (See section [3.2.1](#))

10. Carriage

This part includes 3rd mirror, focal lens, nozzle, and auto focus set. You can move it left, right, forth and back by the keys on control panel. (See section [3.2.1](#))

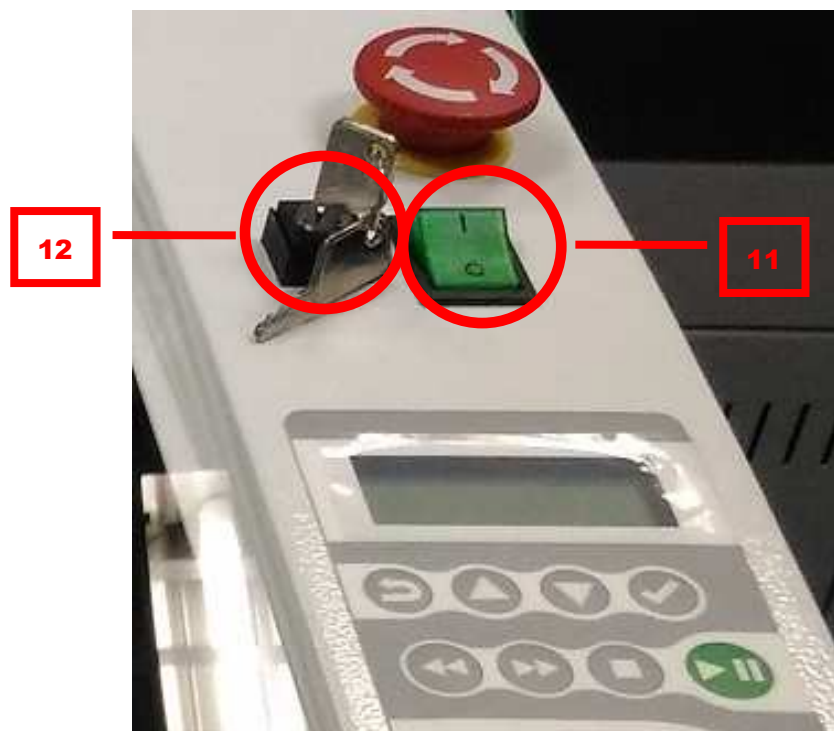

11. Power Switch

This switch can turn on/off the main power of machine.

12. Laser Switch

Please see section [1.3](#)

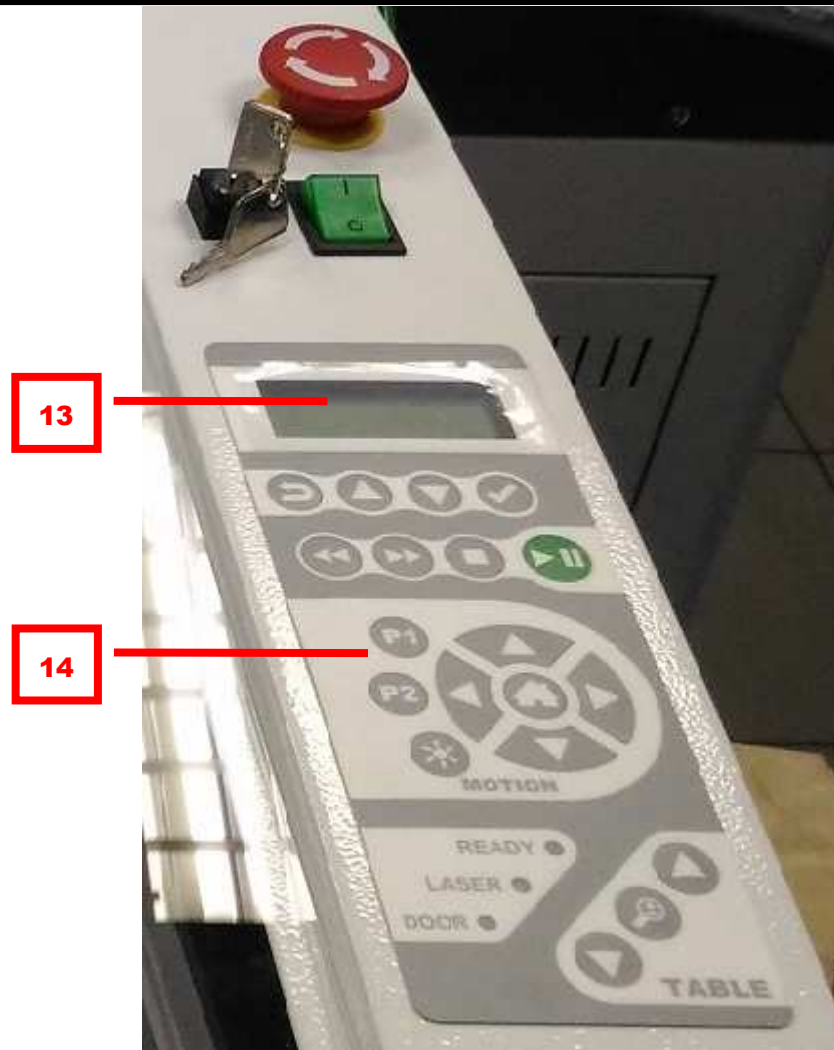

13. LCD Display

LCD display shows the operating menu and information from system. If you want to obtain more detail about operating menu, please see section [3.2.2](#).

14. Control Panel

Control panel provide the keys to operatemachine. If you want to obtain more detail about operating menu, please see section [3.2.1](#).

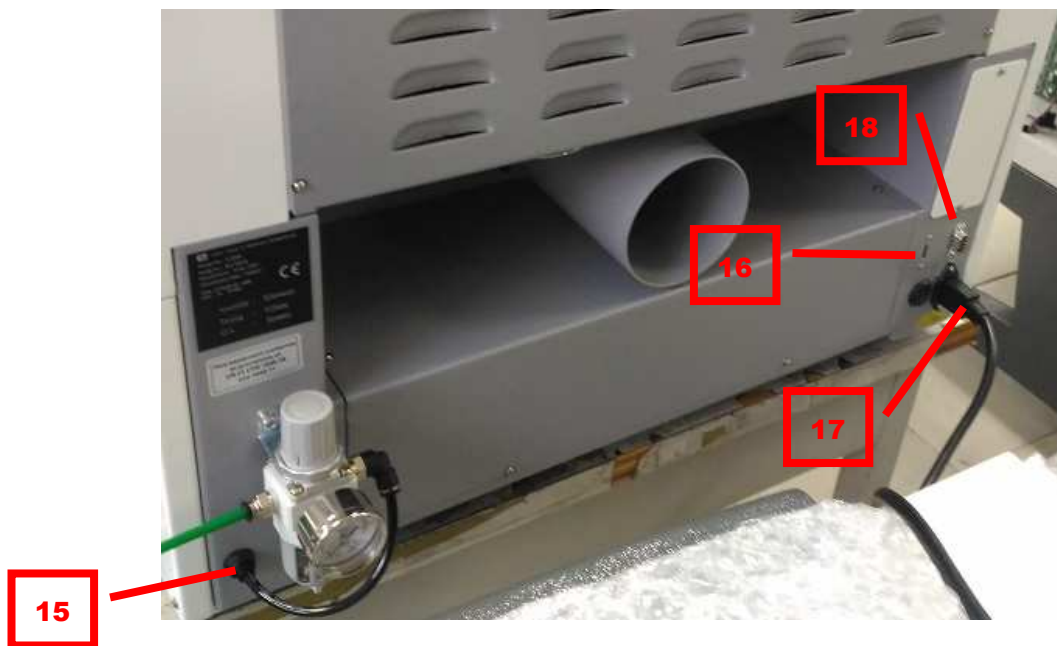

15. Air Assist

Connect a diameter 6 mm hose from an air compressor. The air will go through an air filter and then to window lens and focal lens. It can provide a positive air pressure to protect window lens and focal lens.

16. USB Port

This part can send files from computer to machine through a USB cable.

17. Power Inlet

This part can provide main power through cable from wall outlet.

18. IO outlet

This part provides customer connect to an exhaust system to be controlled by V2000 during the working process.

2.4 Hardware Installation

This section explains the installation steps with other hardware.



1. Check environment

- **Power supply**

Power supply : 110~220 VAC

- **Environment**

Temperature: 0 ~ 30°C, No freezing

Relative humidity : 35 ~ 85 %

Other : Avoid to dust, dirt, oil, mist, strong vibration, or sudden temperature changes

2. Connect AC power cable



3. Connect USB cable from computer to machine



4. Connect a pipe from exhaust port to blower



5. Connect a hose to an air compressor



2.5 Driver Installation

2.5.1 Uninstall Driver

This section explains the installation steps for driver on computer. Here use a iLaser4000 and Windows 7 as an example to demo the installation.

Please make sure you have administrator permissions on this computer. And connect machine to computer before installation.

1. Check computer equipment.

A High speed computer will calculate image file quicker and take less time to send files to machine. Generally speaking, the computer requirement depends on what software do you use. So you should check the requirement for the software and then it can work well with our printer driver.

2. Put the CD-ROM of installation into CD/DVD drive

3. Go to the [Devices and Printers] window and select the [Add a printer] option.

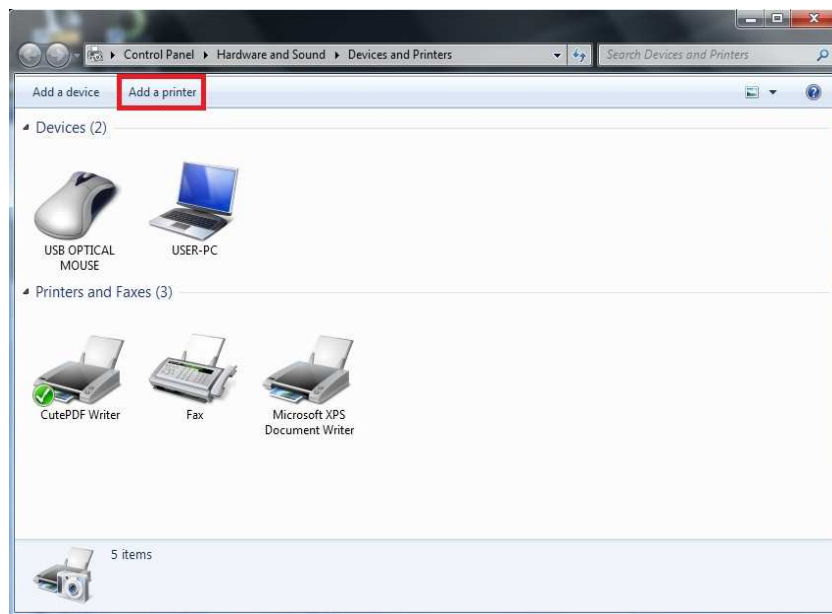

4. Select [Add a local printer], then click the [Next] button.

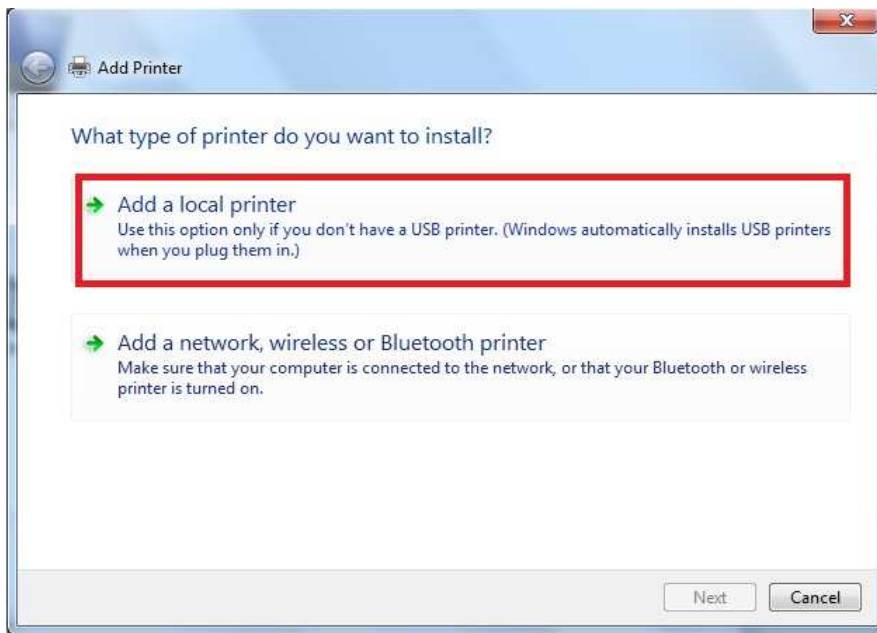

5. Select [Use an existing port], and select [USB00* (virtual printer port for USB)], then click the [Next] button. (The * is depended on the USB port that is connected with laser machine)

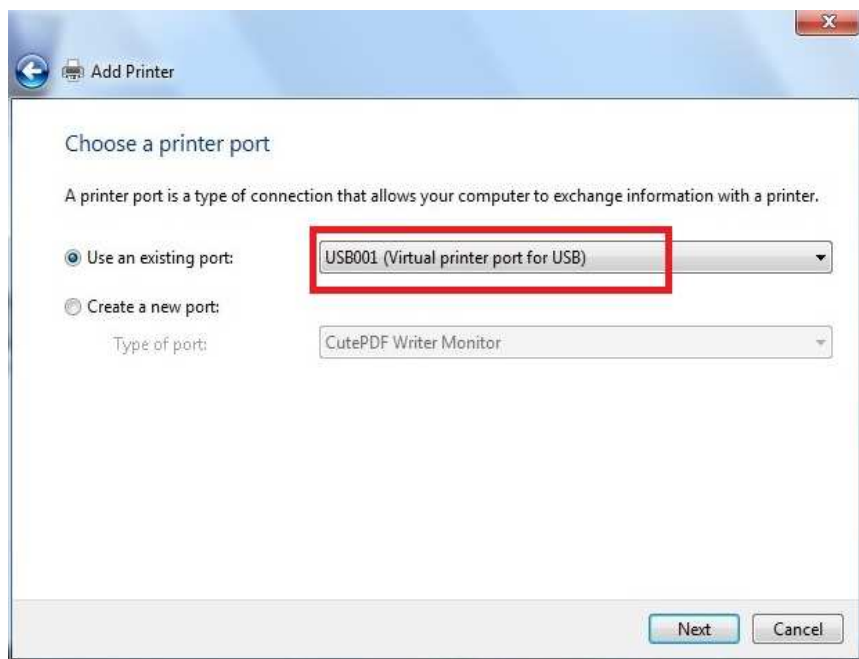

6. Click [Have Disk...]

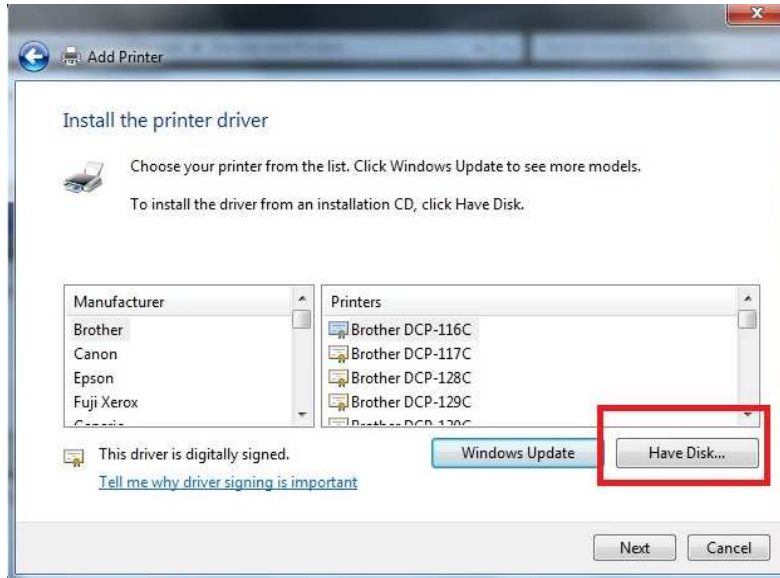

7. Click [Browse...] button

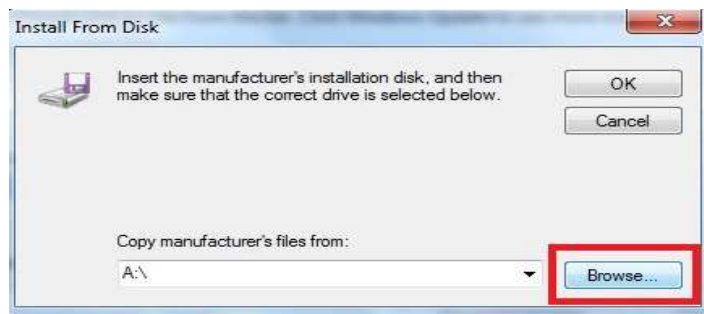

8. Select the inf file

Browse to the location of inf file. If it is on a CD-ROM, please browse to the CD-ROM. Select the *.inf file which matches with your machine type.

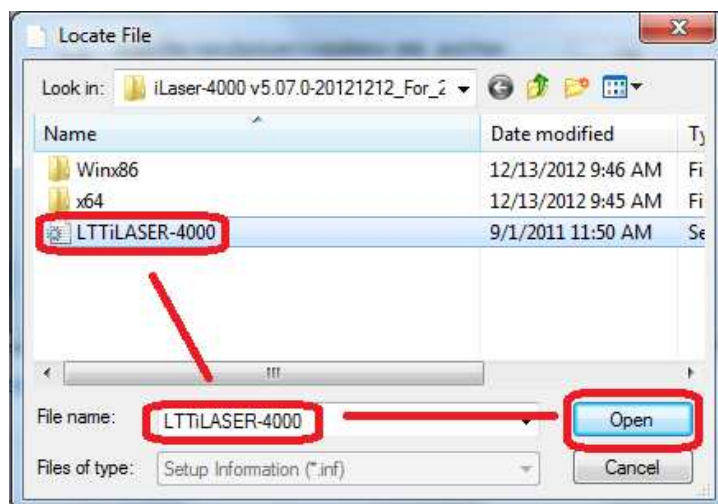

9. Click [Next] button

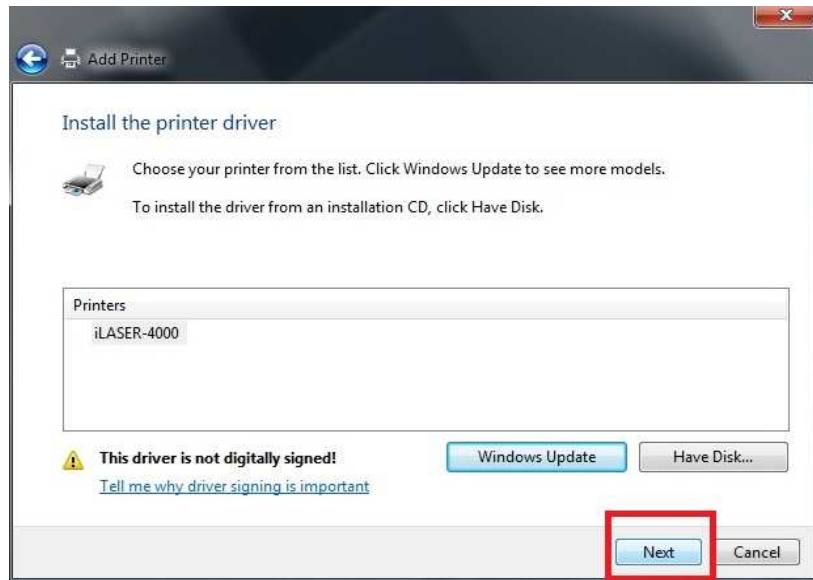

10. Click [Next] button

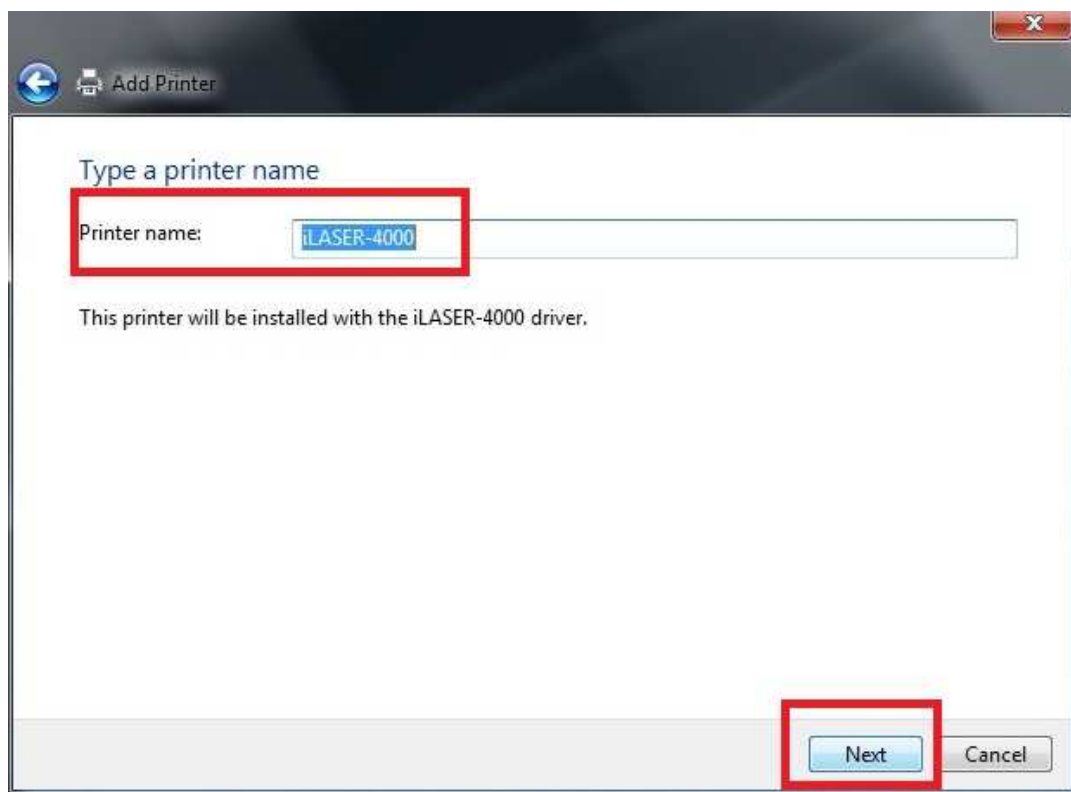

11. Select [Install this driver software anyway] to continue the install.



12. Click [Next] button

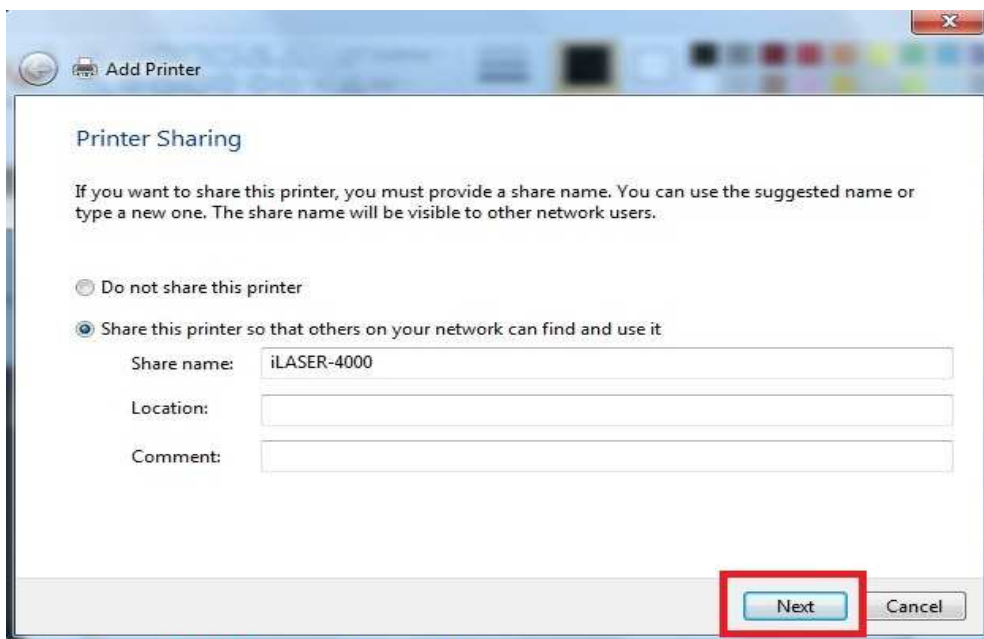

13. Click [Finish] button

If you want this machine to be the default printer, then please check [Set as the default printer]. If there are no other drivers installed on your computer, the new added printer will automatically be set as your default printer.

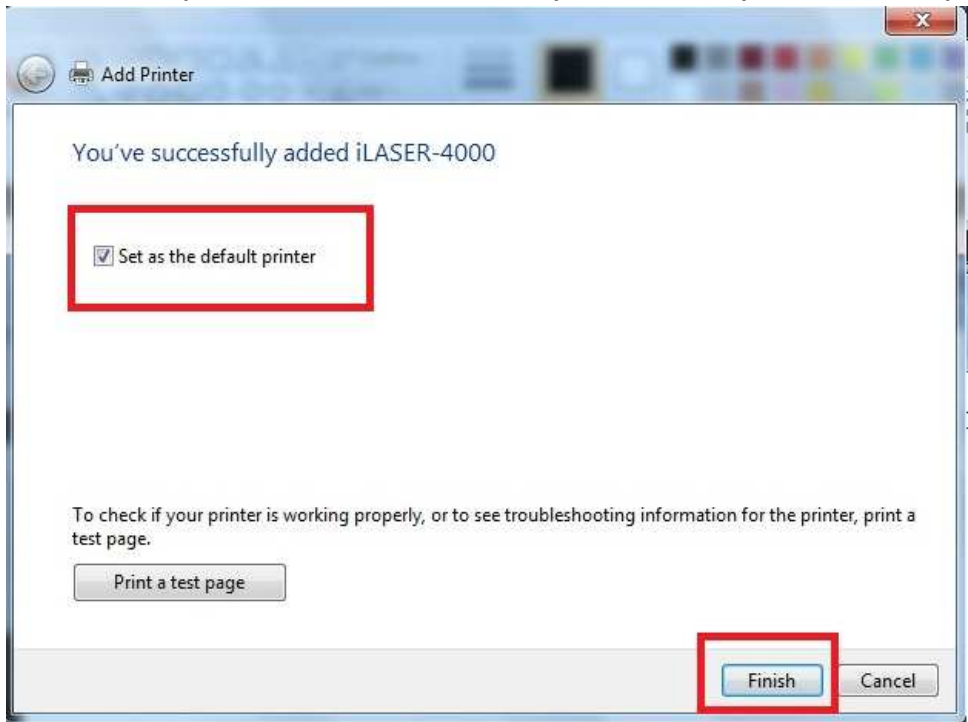

14. Right click the print [V2000] then select the [Print Preferences]. and select the [version], then you can check the diver vision.

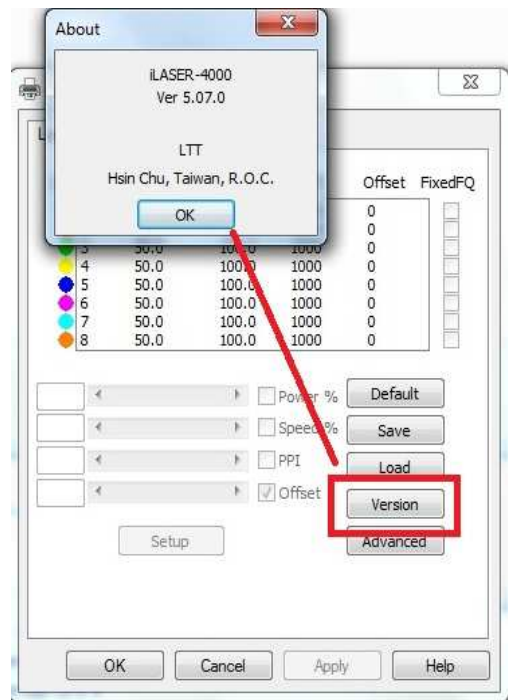

2.5.2 Uninstall Driver

- 1 Go to the [Devices and Printers] window
- 2 Select the Printer you want to delete and then press the [Remove device] button.

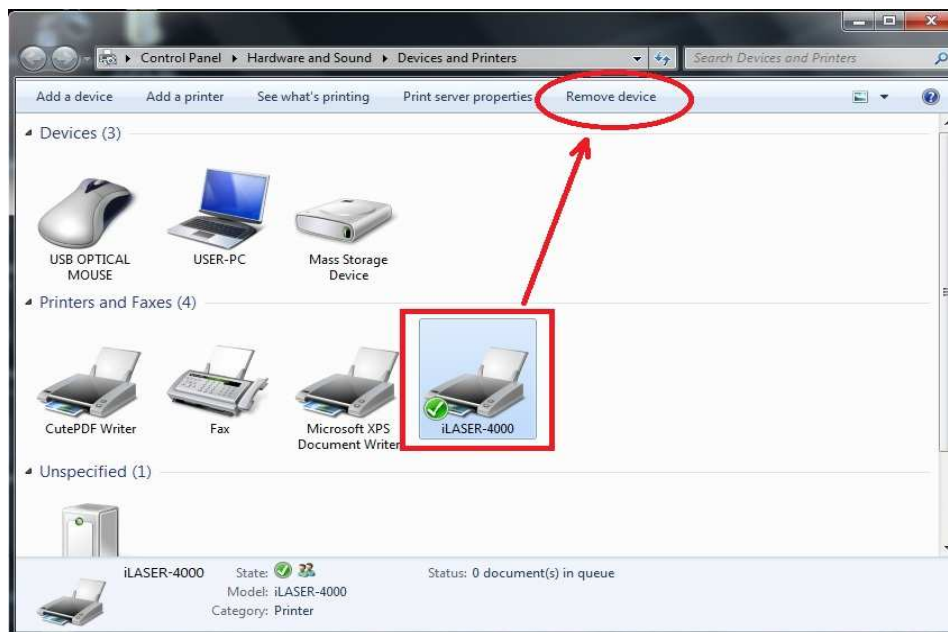

- 3 Press the [Yes] button to remove the printer.



4. After remove the printer, select any printer and press [Print server properties]



5. Select the [Drivers] page and select V2000 then press the [Remove...] button

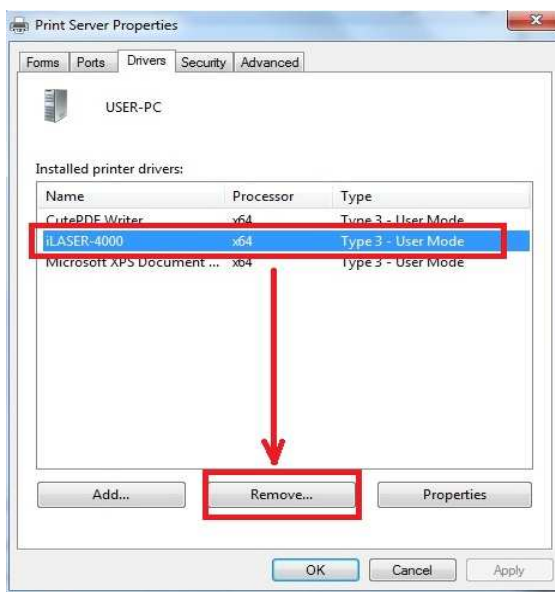

6. Select [Remove driver and driver package].



7. Press the [Yes] button to confirm the uninstallation.

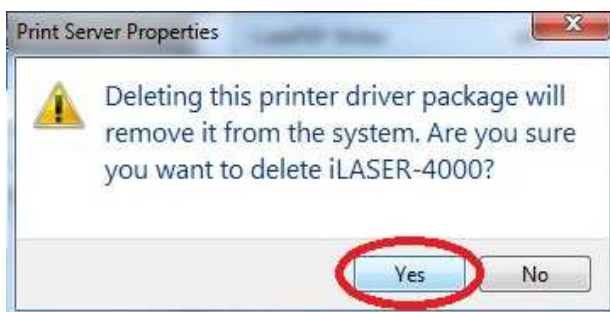

8. Press the [Delete] button to continue.

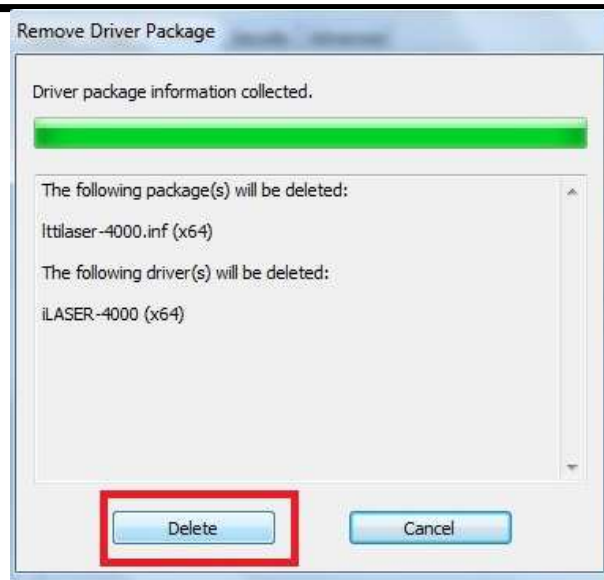

9. Press the [Close] button to finish the uninstallation process.

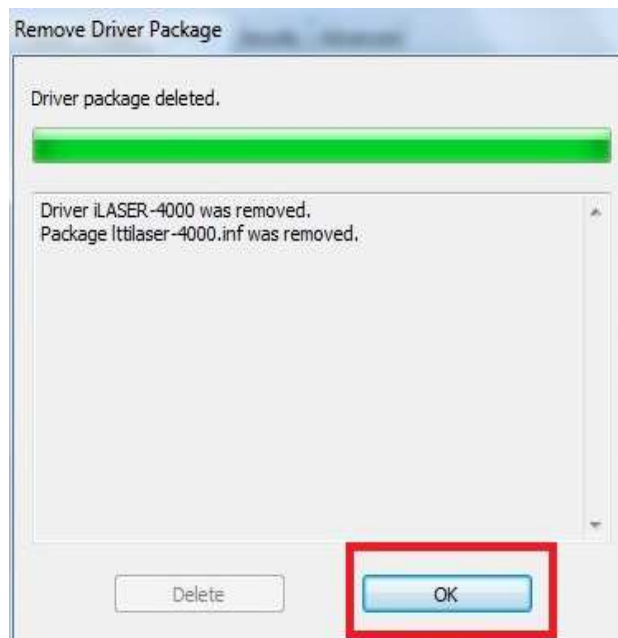

10. Close the [Devices and Printers] window.

11. Go to [Computer]→[c:]→[LTT], then remove all file under the folder.

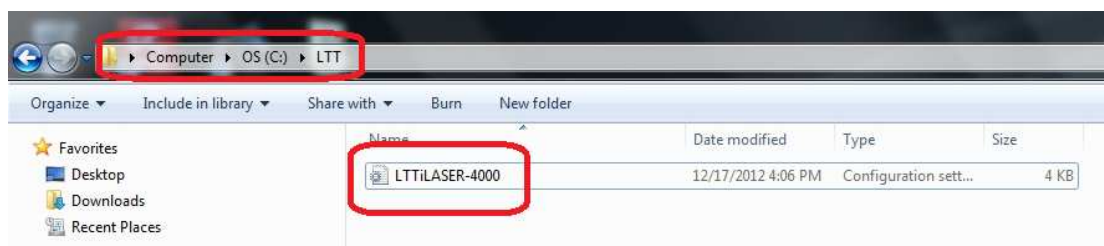

2.5.3 Change USB Cable to Another Port

This section explains that the steps when change USB port.



Once you connect the USB Cable to computer, we strongly suggest that do not change it to another USB port. If you must change USB cable to another port, you have to also change the printer settings of V2000. If this happens, please follow next steps.

1. Connect the USB cable to another port well with V2000.
2. Open **[Printer and Faxes]** window or **[Devices and Printer]** window

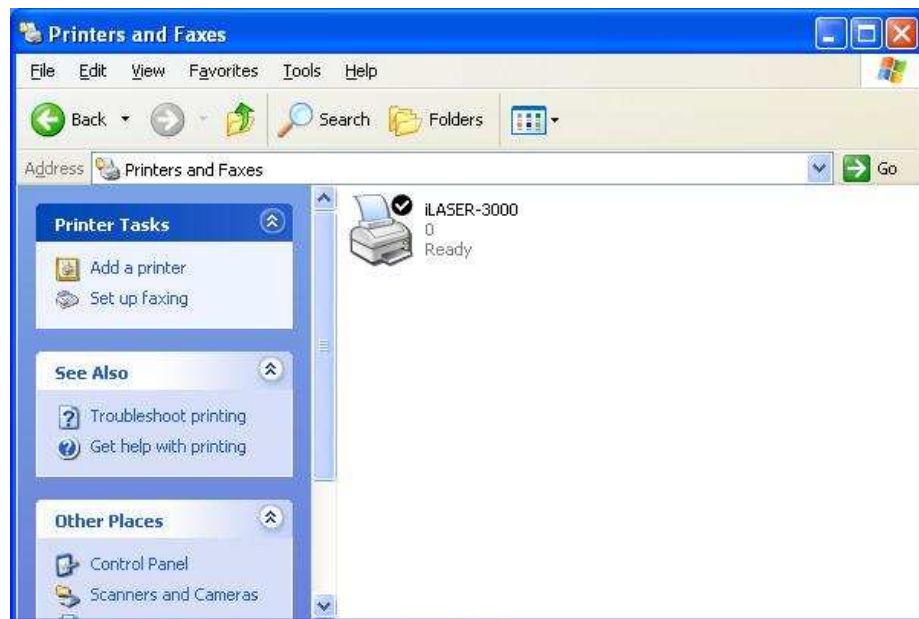

3. Right click V2000 printer and select **[Properties]** or **[Printer Properties]**



Chapter 2 Installation

4. Switch to **[Ports]** label. Switch the **[USB00*]** which is belong to the new port and click **[OK]**.

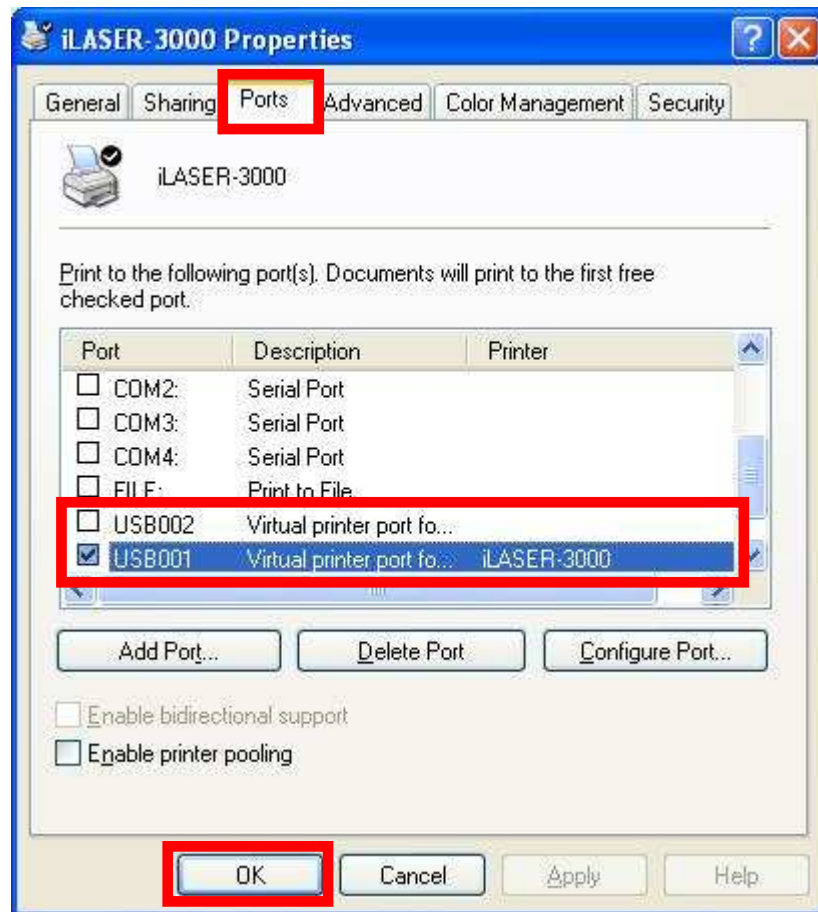

5. Done.

2.6 CorelDRAW Setup

1. Layout setup

It is strongly recommended to keep the graphic software's page size the same with driver's page size before you begin editing files. Here you will learn how to setup your page and learn how to keep those settings that you don't have to setup again next time. If you are an AutoCAD user, please see section 2.7.

Go to [Layout]→[Page Setup...]

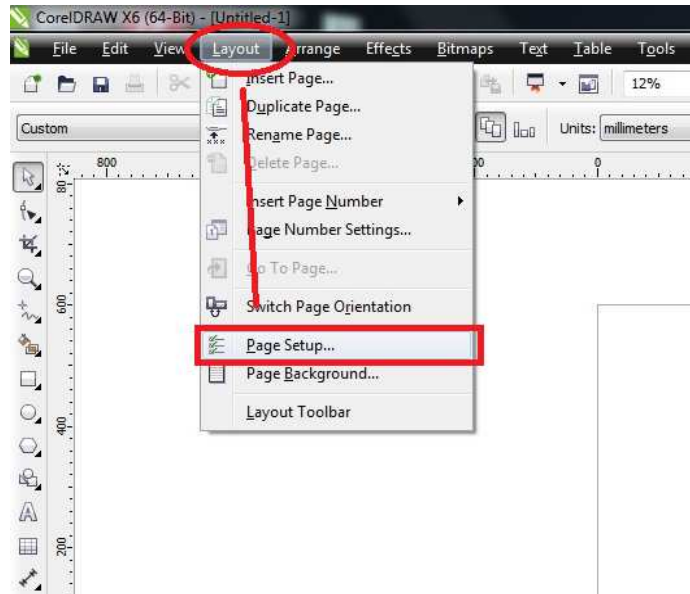

Modify [Width] and [Height] according to work area (See Appendix 1). And click [Save Custom Page] button.

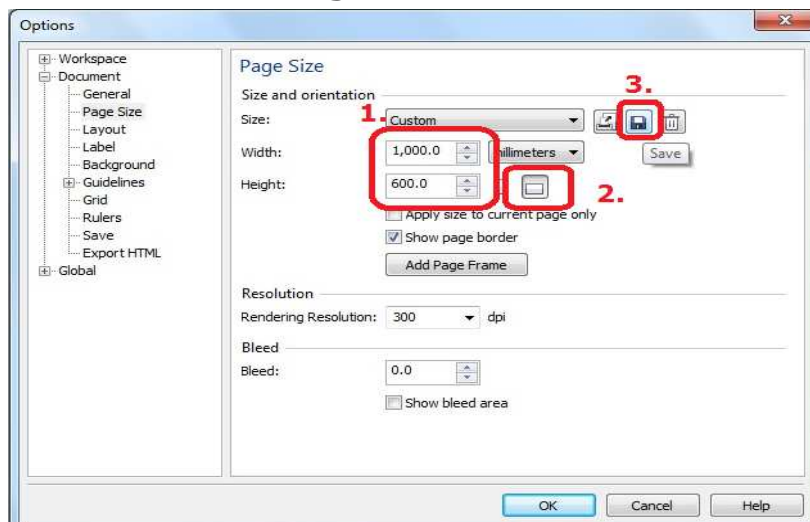

Name this paper type. It is recommended to name with the machine type. Then click [OK] to save.

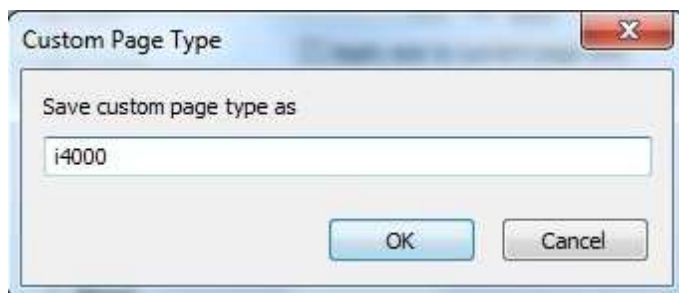

Click [OK] to complete the paper size adjustment.



Next time you can select template style while you create a new file.

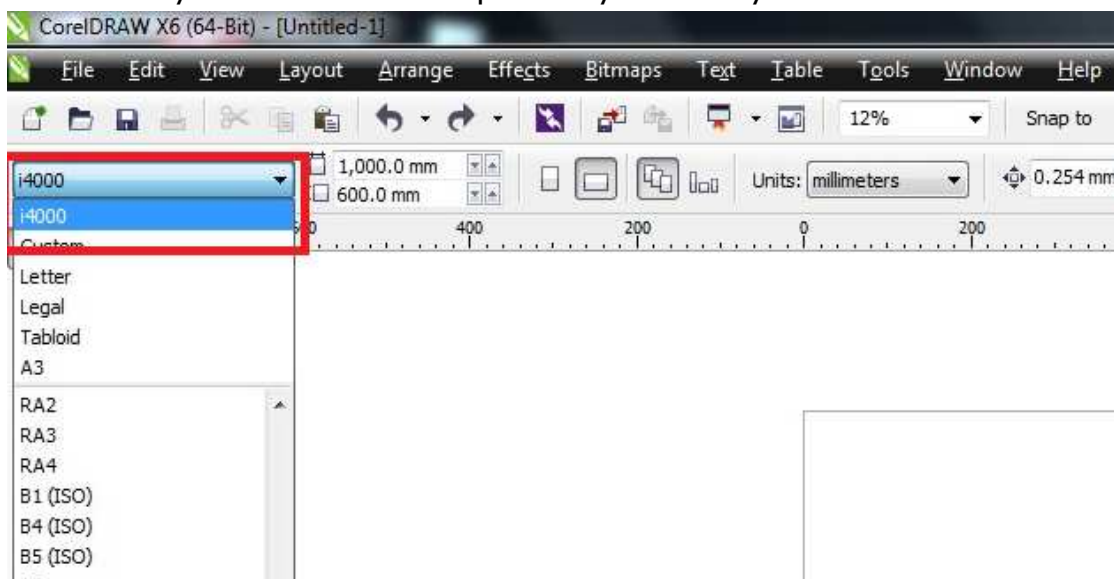

To active victor cut mode, please set the [linewidth] to [hairline]

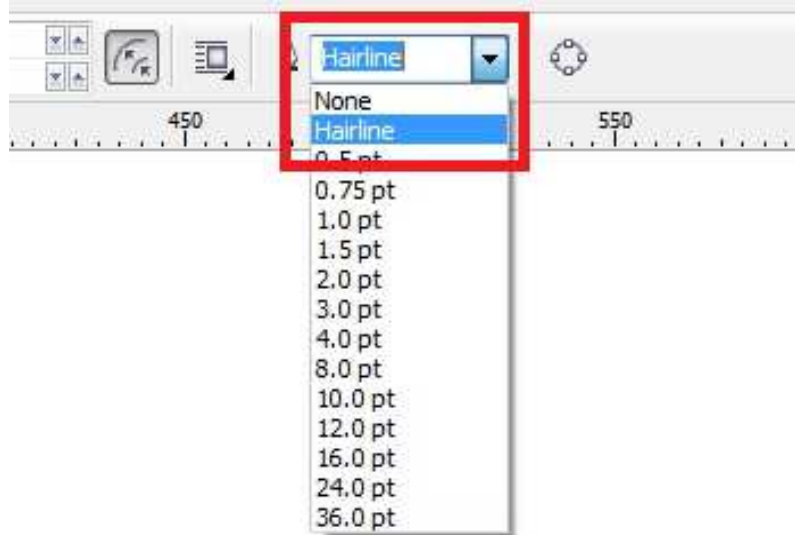

2. Print setup

Go to [File]→[Print...]

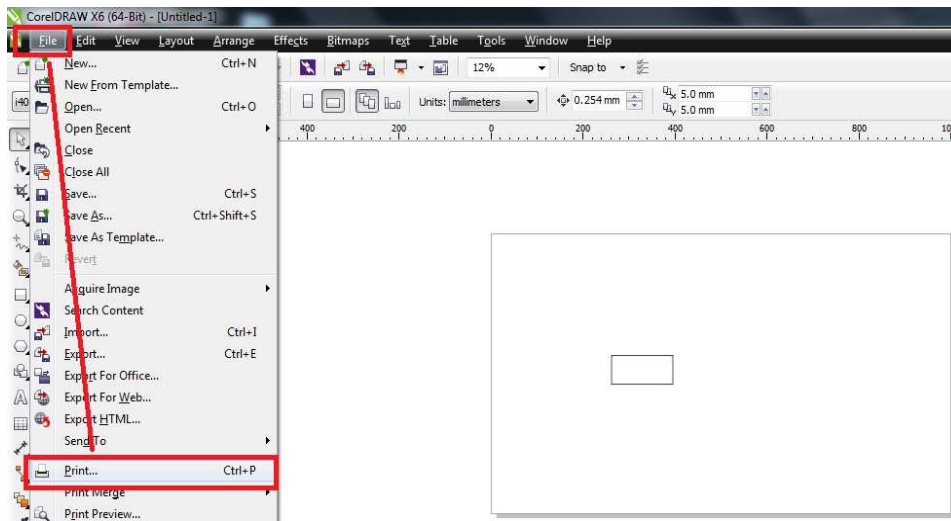

When the [Print] window shows, select printer driver and click [Properties] button.

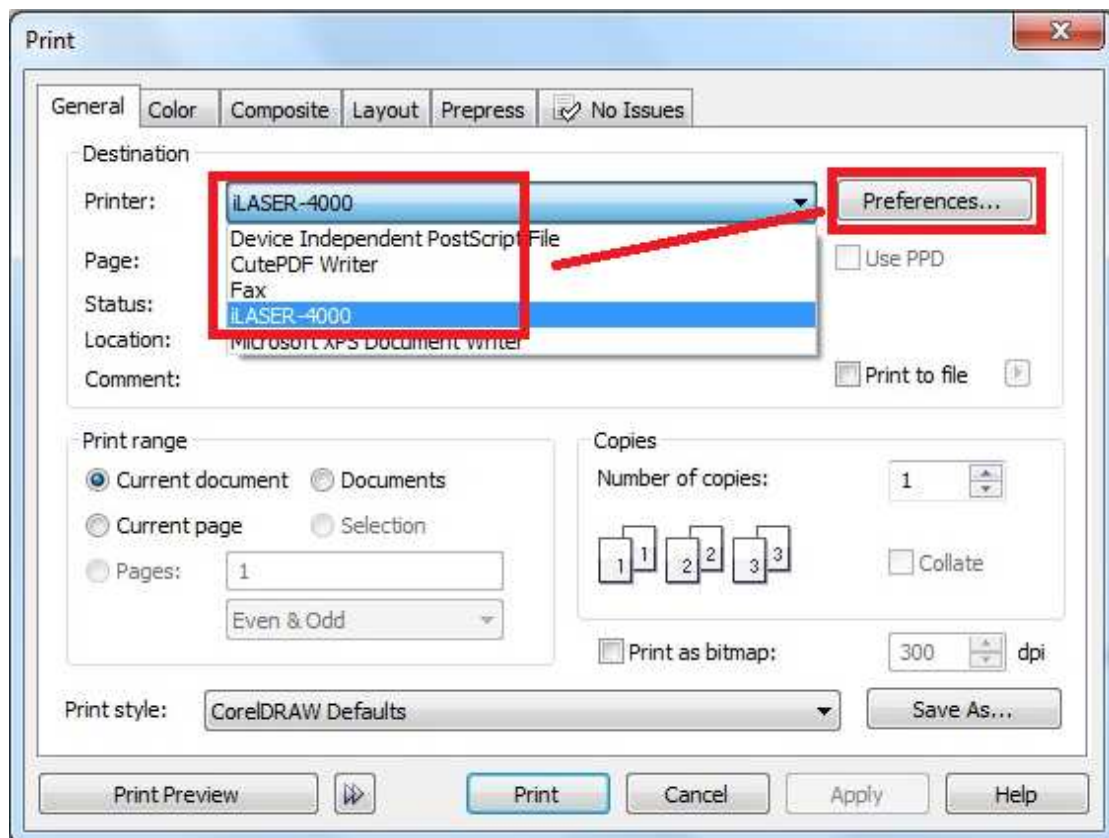

Modify Laser settings if you need. Press [OK] to finish driver setting.

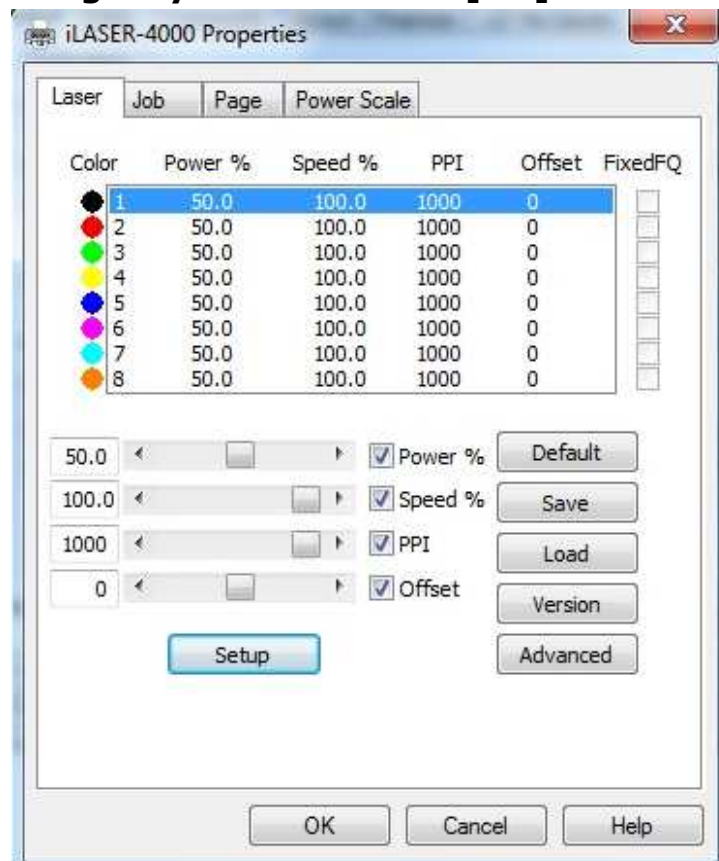

2.7 AutoCAD Setup

Here you will learn how to setup the page and print setting on AutoCAD.

1. Page And Layout Setup

Open the AutoCAD. Type **[limits]** on the command line then press **[Enter]** key.

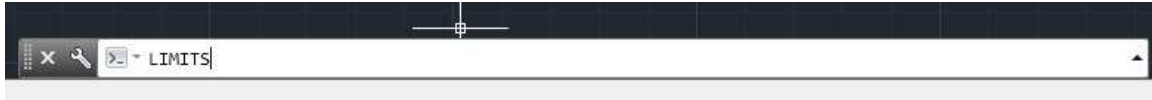

Then press **[Enter]** key to set the bottom left corner to **[0,0]**.

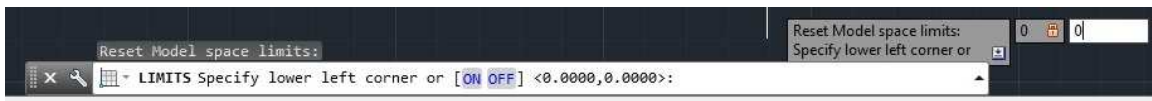

Setting the top right corner according to work area ([Appendix 1](#)). Then press **[Enter]** key.

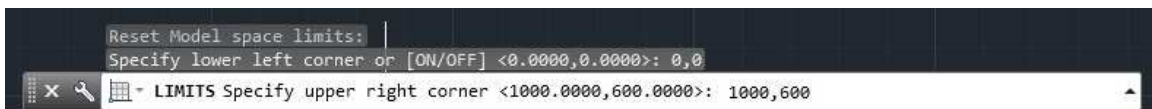

Turn on the grid by typing **[grid]** → **[on]**. This shows the page area so that can help user to see boundary.

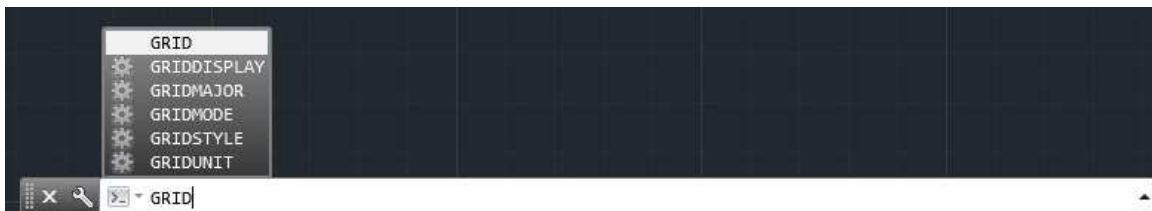

Choose **[File]** → **[Save as]**. Then select **[Files of type]** as **[*.dwt]**. Set filename as machine type and then press **[Save]** button to save the Template style.

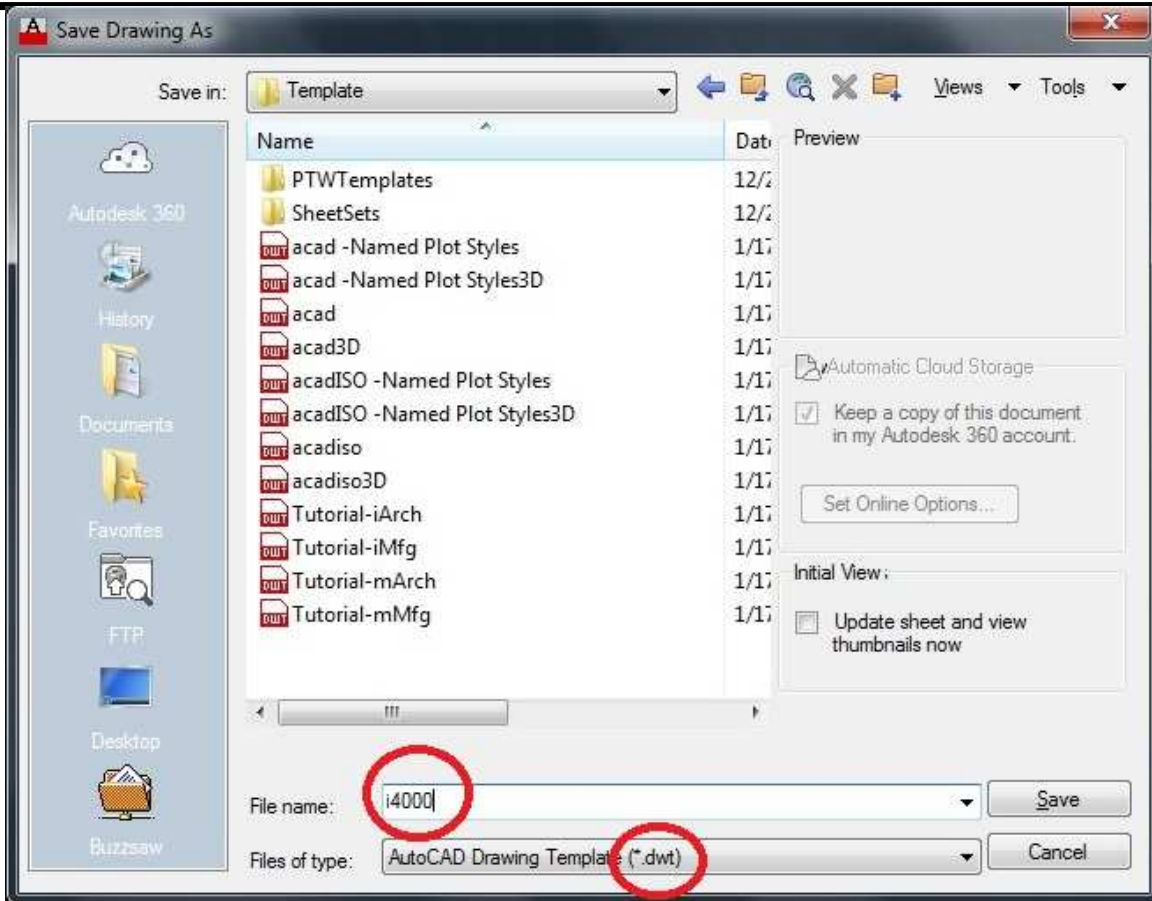

You can select the template file you created whenever open AutoCAD. Nexttime when you use the same page size, you can use the template file directly so that you don't have to setup the page anymore.

2. Print Setting

Select the **[A]** mark at left-up corner then select **[Print]**→**[Plot]**.

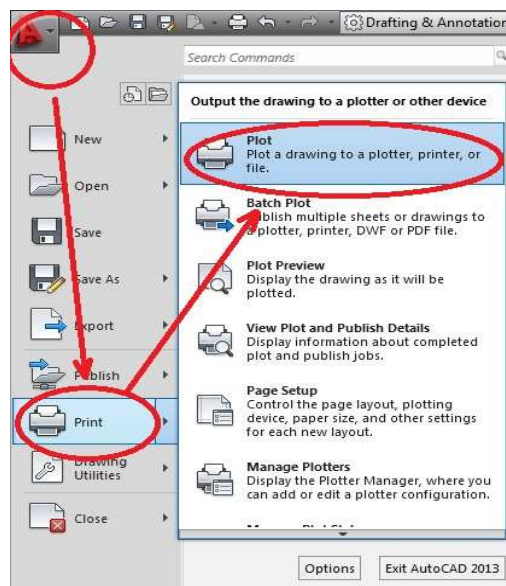

When the **[Plot]** window shows, select printer driver and click **[Properties]** button.

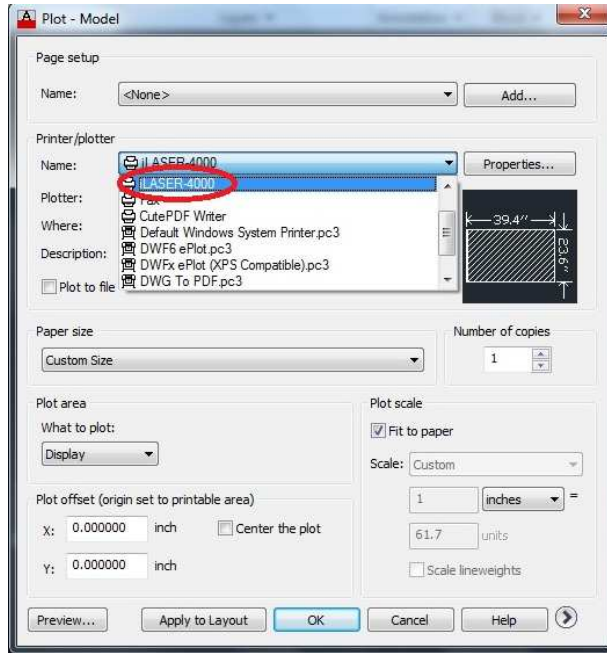

Select **[Modify Standard Paper Sizes]** on the tree-list box. Select the option **[Custom Size]**. Press **[Modify]** button.

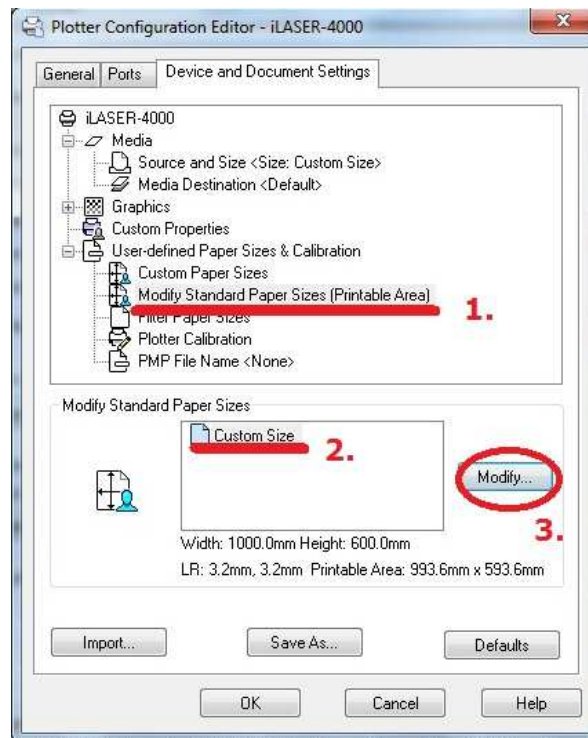

Modify **[Top]**, **[Down]**, **[Left]** and **[Right]** to zero, press **[Next]** button to continue.

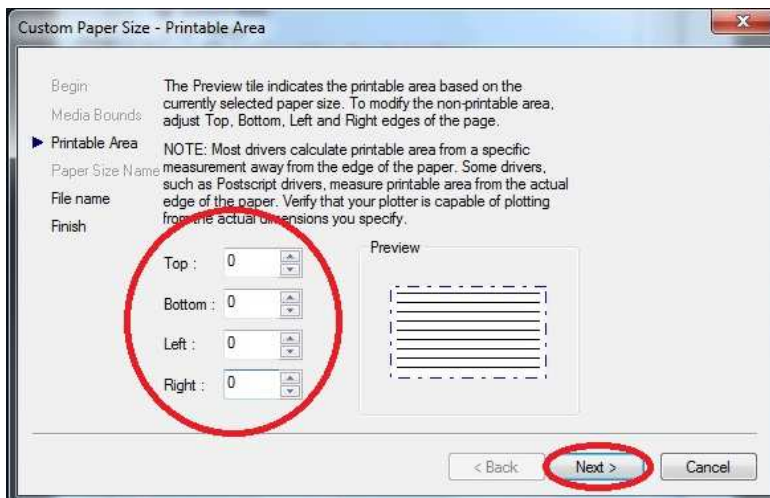

Confirm the **[File name]** then press **[Next]** button to continue.

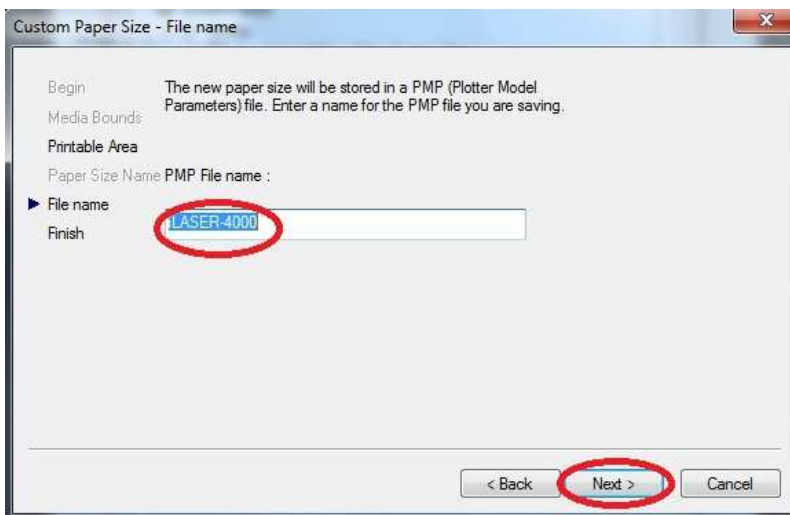

Press **[Finish]** button to continue.

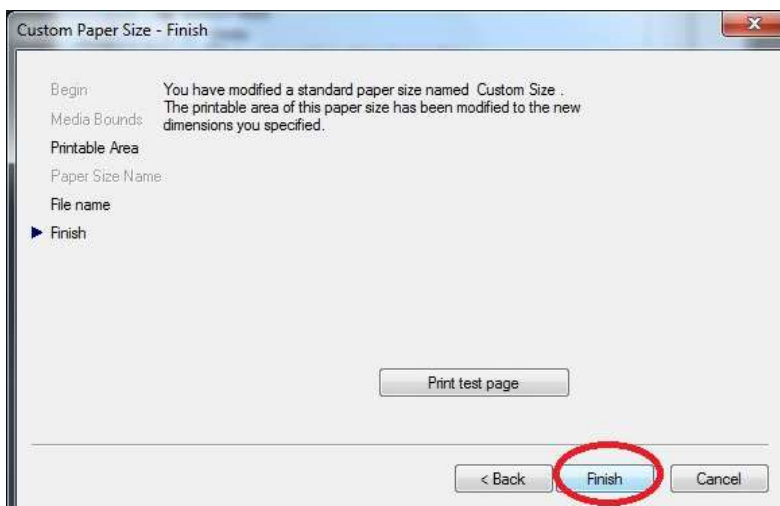

Select **[Custom Properties]** and click **[Custom Properties]** button at middle.

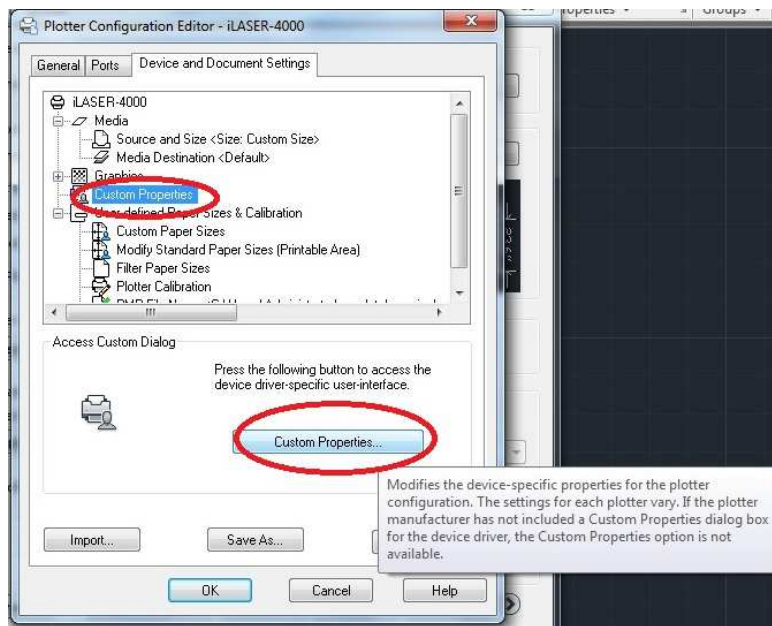

Modify Laser settings if need. Press **[OK]** to finish driver setting.

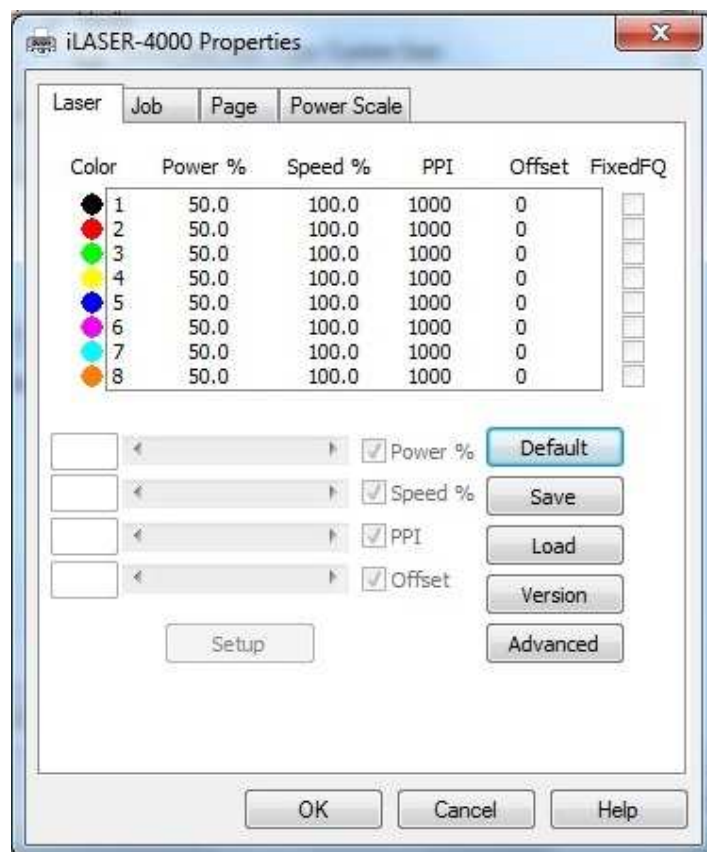

Chapter 2 Installation

Press **[OK]** to back to print setting.

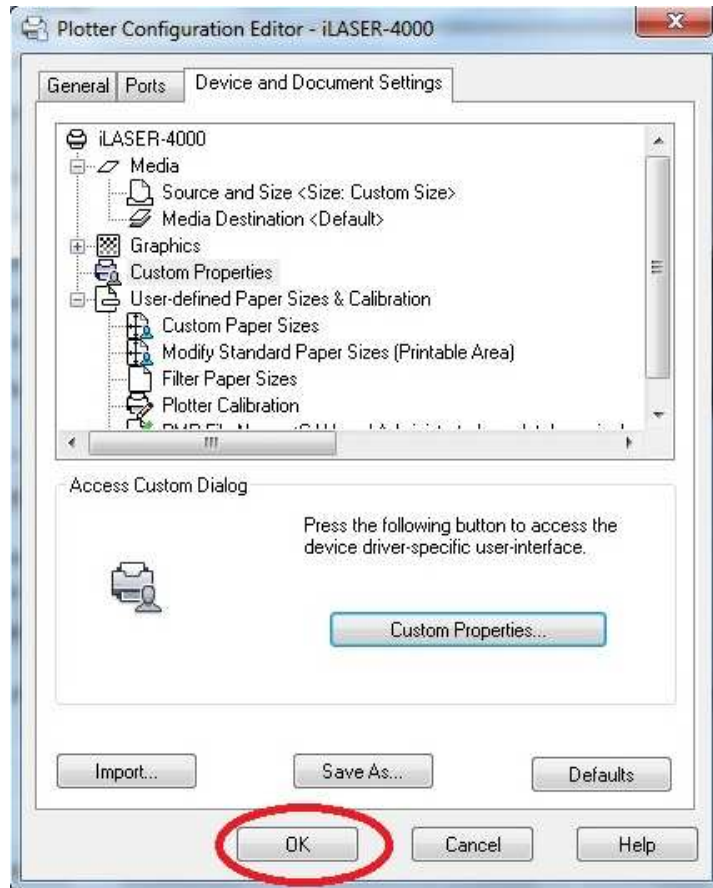

Select [Save changes to the following file] and press **[OK]** to continue.

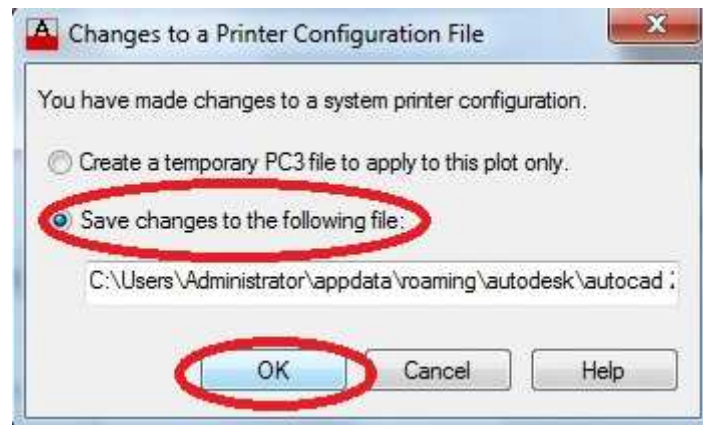

Chapter 2 Installation

Press **[Yes]** button to continue.

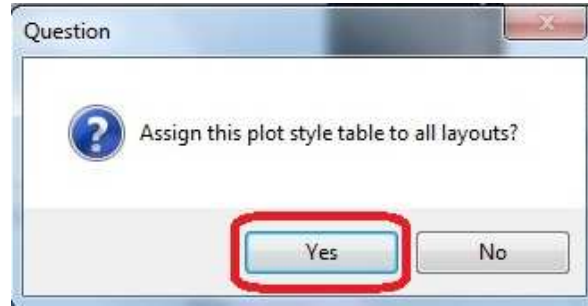

Use **[Shift]** key to help selecting all colors in **[Plot styles]** list. Set the **[Linetype]** to **[solid]** and the **[Lineweight]** to **[0.0000 mm]** Then press **[Save& close]** button to continue.

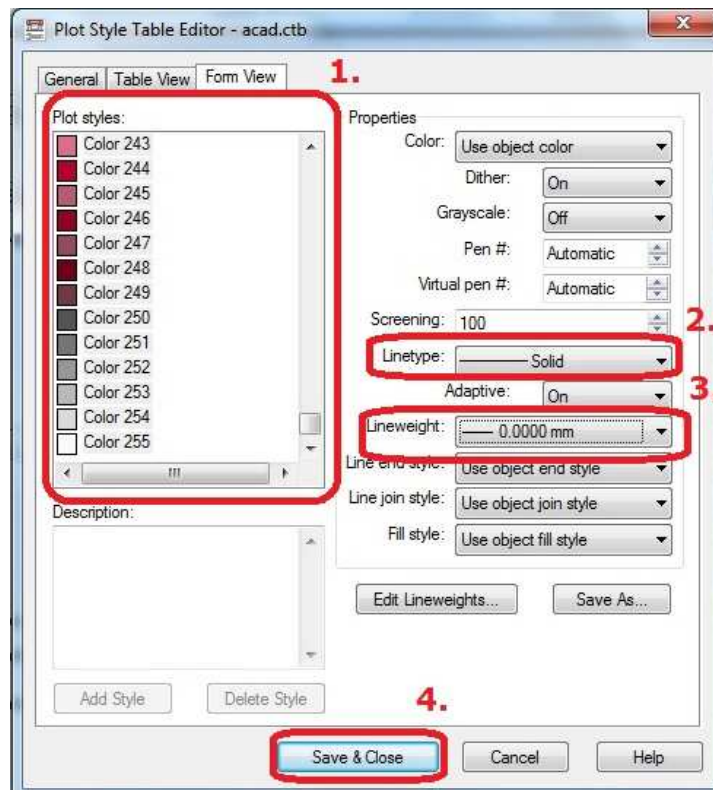

Chapter 2 Installation

Please follow the settings below. Switch to **[Plot Settings]** tab. Select the **[Plot scale]** to **[1:1]**. Select the **[Plot area]** to **[Limits]**. The **[Drawing orientation]** should be set to **[Landscape]**. Then Press **[OK]** to send file to machine.

Before you sent the file to machine, you can click the **[Apply to Layout]**, it will help you to save all these setting to the file. When you open it next time, it will save a lot of time to choose all these settings.

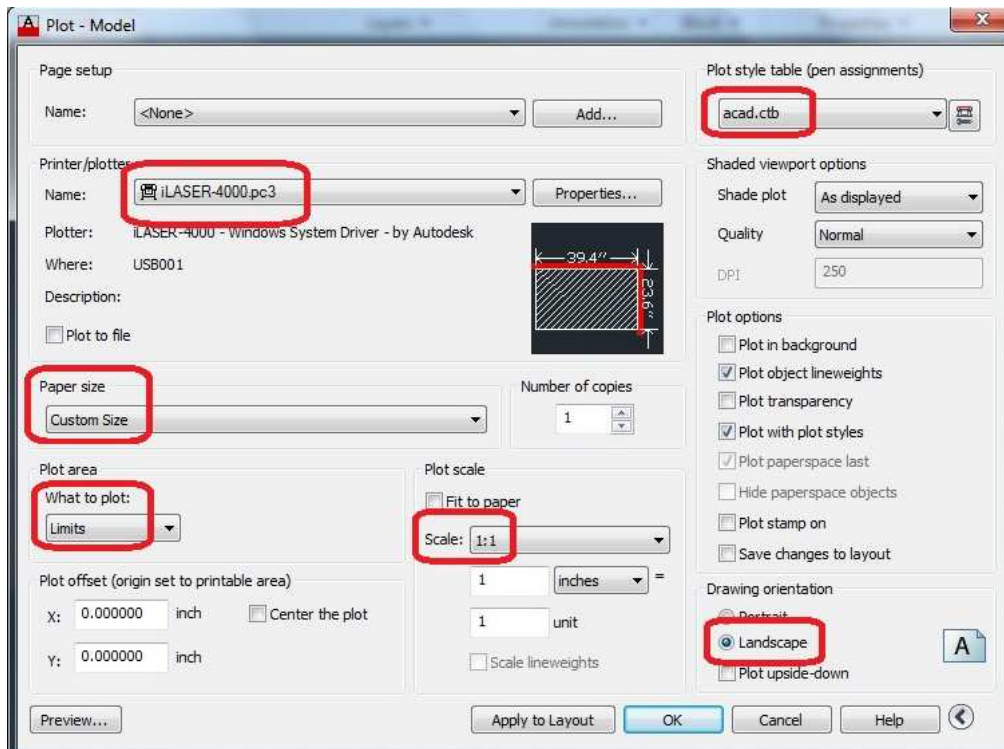

2.8LTT Product Tools

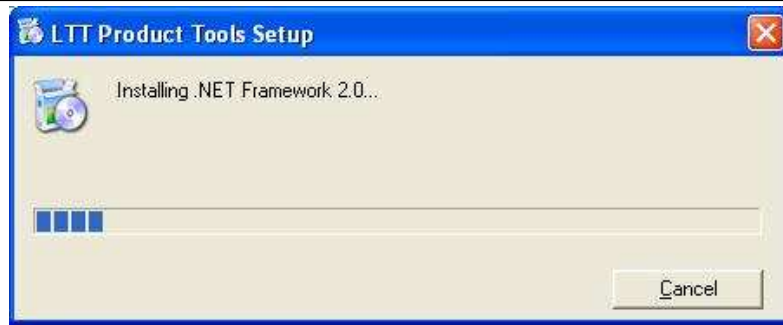

4. When you see the diagram below, please press the **[Next]** key to go on.

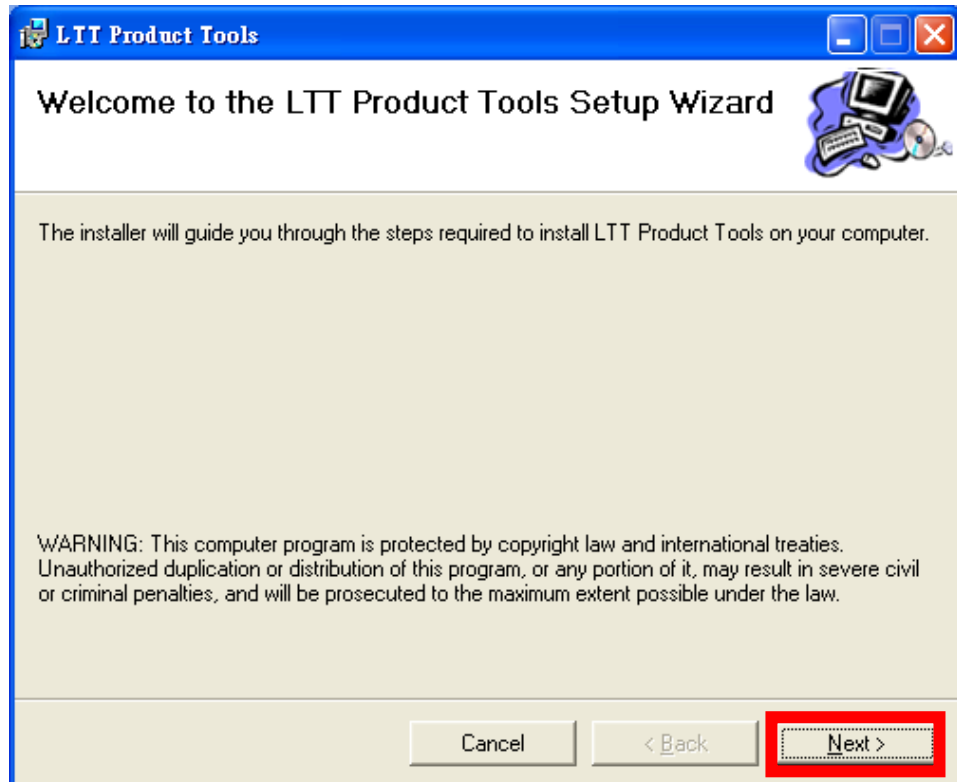

5. When you see the diagram below, please choose a position to install the software and press **[Next]** key to go on.

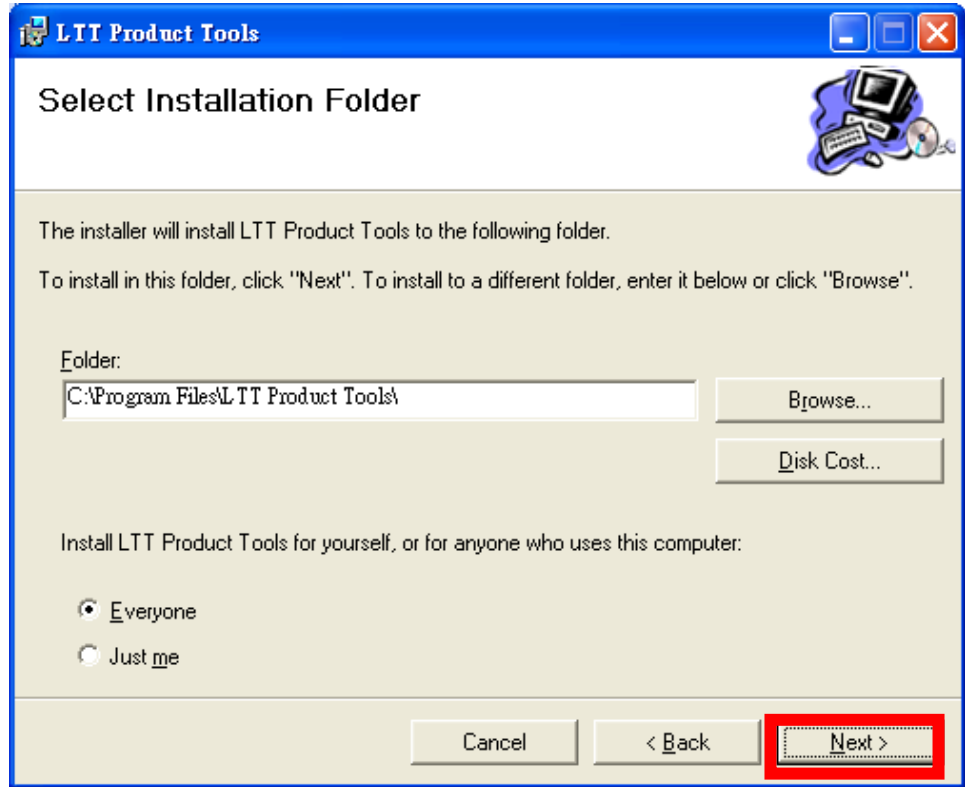

6. Press **[Next]** key to go on.

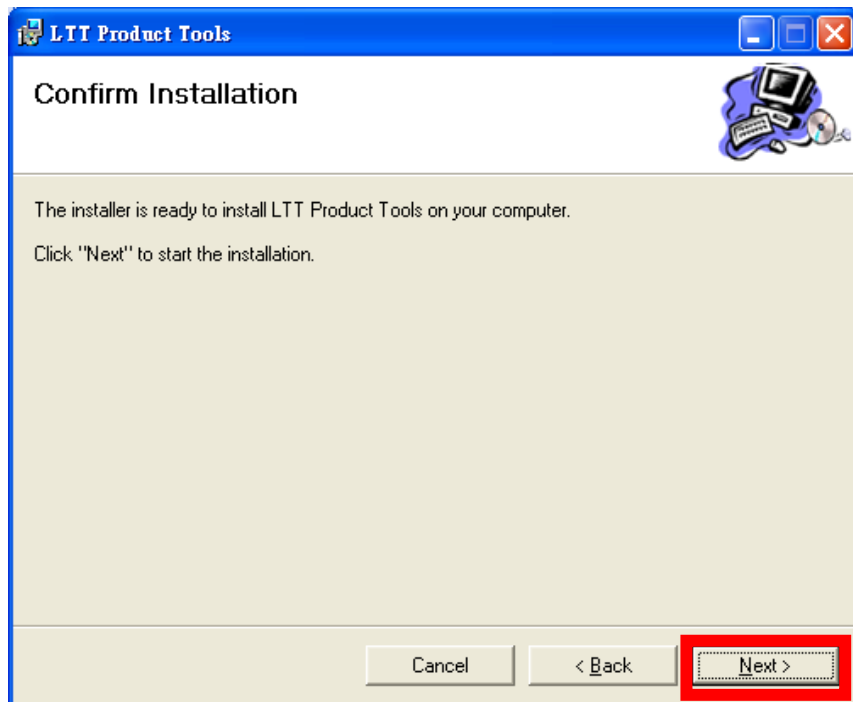

7. Press **[Close]** key to finish the setup procedure.

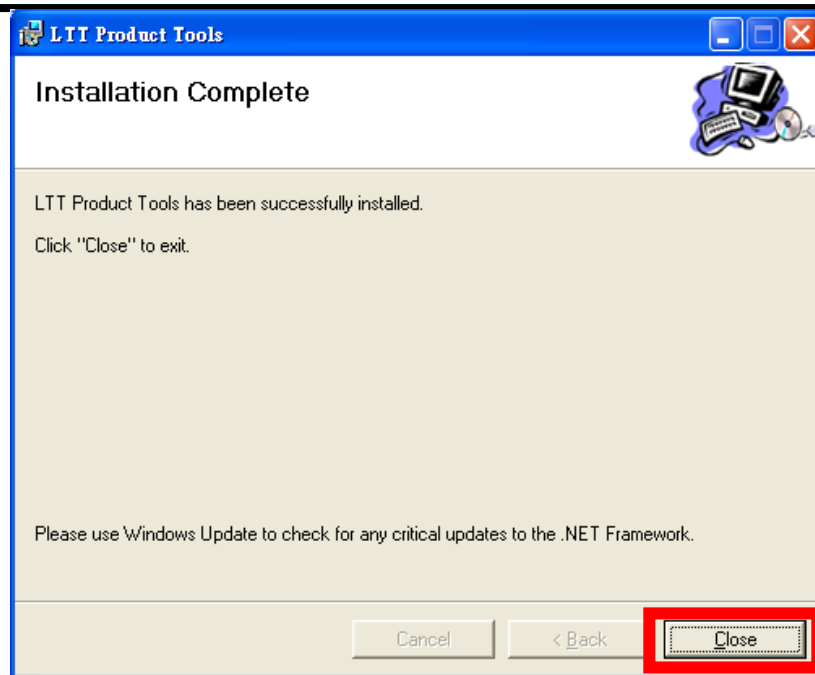

8. After the setup procedure, you can open the software from two shortcuts. The first one locates on the **[Desktop]**, and the second one is placed in the **[Start Menu]**.



2.8.2 Uninstall Procedure

1. Click **[Start]**→**[Settings]**→**[Control Panel]**

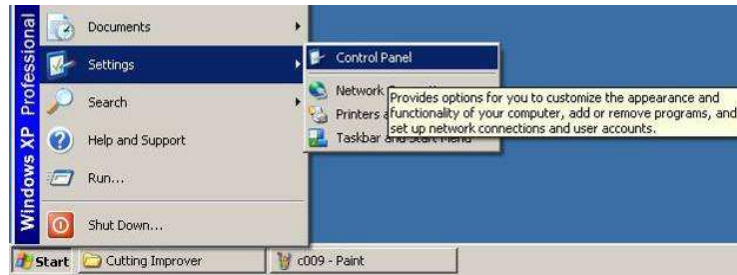

2. Double click **[Add or Remove Programs]**

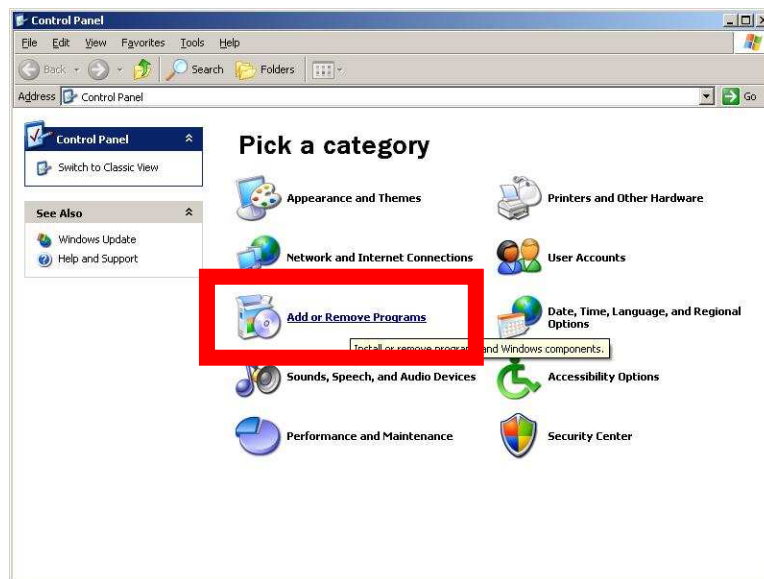

3. Click **[LTT Product Tools]**→ Press **[Remove]** key

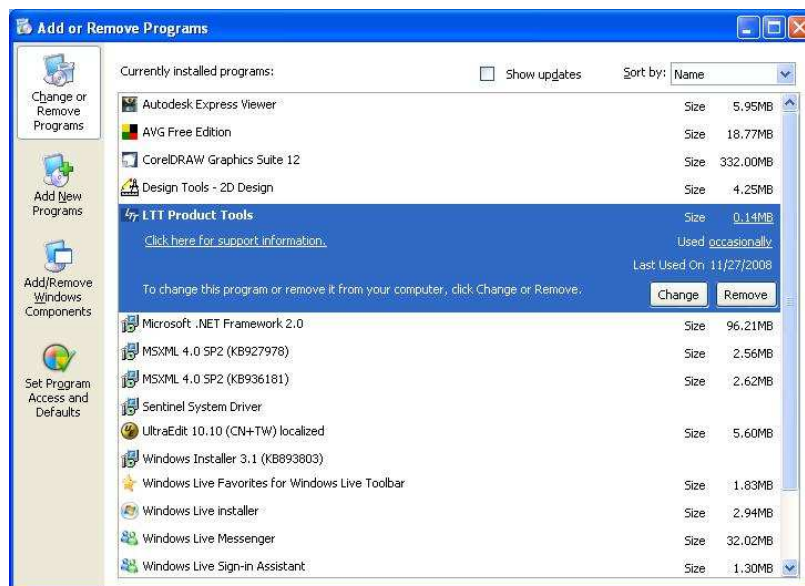

4. Please choose **[Yes]**

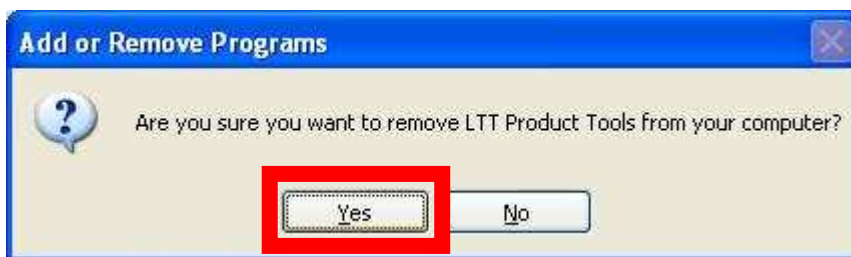

5. Done

Chapter 3 Operation

3.1 Operator Position

This section shows the position when you operate machine.

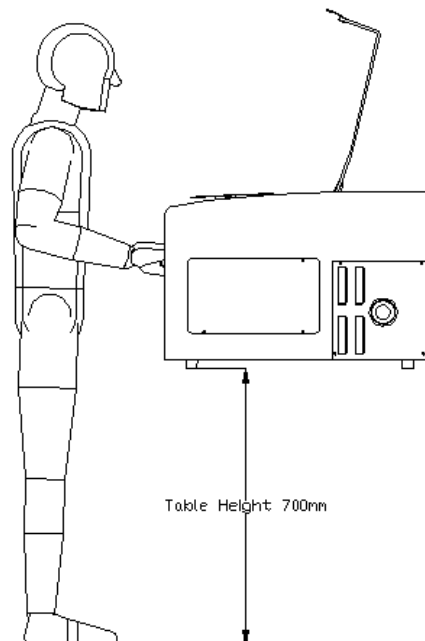
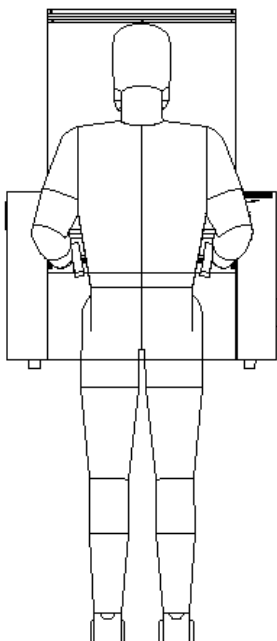
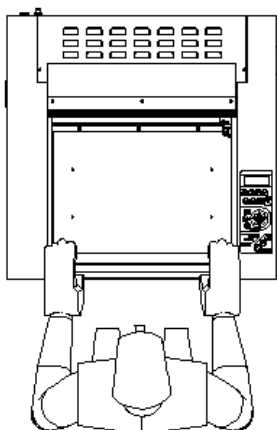

3.2 Basic Operation Flow

This section explains the basic and common steps to operate V2000. If you want to obtain more detail about operation, please see section [3.3](#) and [3.4](#).

Before process the steps in this section, please make sure that you have already finished all steps in chapter 2.

1. Get machine ready.

- Turn on the power.
- Wait for homing process finishing.

2. Send file to machine.

- Open a drawing file or draw a new one on CorelDraw or AutoCAD.
- Execute the **[Print]** or **[Plot]** function.
- Modify the settings of driver. (See section [3.4](#))
- Click **[OK]** to send file.

3. Adjust focal height (if necessary).

- Put the material on the table.
- Move the carriage above the material.
- Press  select **[Yes]**.

4. Execute file.

- Select the file on control panel.
- Make sure all LED indicators on control panel are on. (If not, see [chapter 5](#))
- Press  start file.

3.3 Machine Operation

This section explains the detail about how to operate V2000.

3.3.1 Control Panel

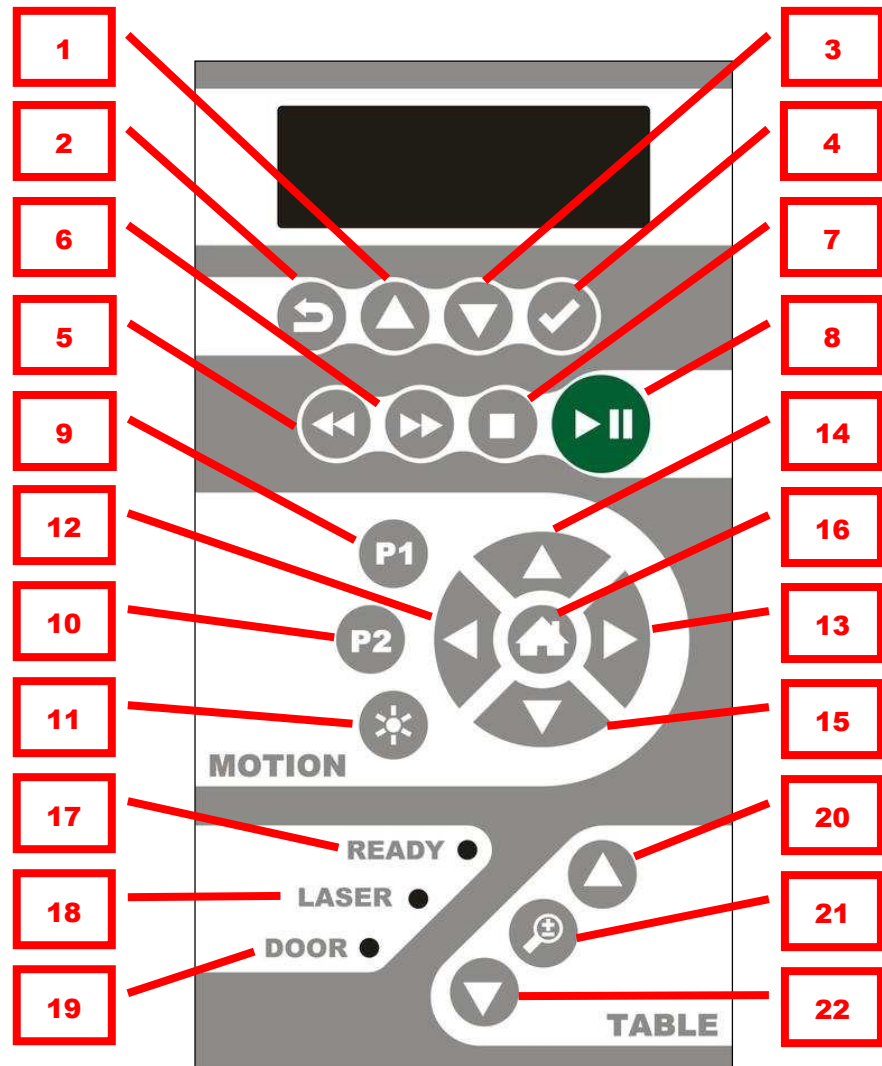

- | | |
|----------------------------------|--------------------------------|
| 1. Cursor Up / Increase Values | 12. Move Carriage Left (X-) |
| 2. Escape | 13. Move Carriage Right (X+) |
| 3. Cursor Down / Decrease Values | 14. Move Carriage Forward (Y-) |
| 4. Enter | 15. Move Carriage Back (Y+) |
| 5. Previous File | 16. Homing |
| 6. Next File | 17. Ready Indicator |
| 7. Stop | 18. Laser Indicator |
| 8. Run / Pause | 19. Door Indicator |
| 9. Move to P1 | 20. Table Up |
| 10. Move to P2 | 21. Auto Focusing |
| 11. Red Beam Switch/ Lase | 22. Table Down |

1. Cursor Up / Increase Values

Move the cursor up or increase values.

2. Escape

Escape from sub-menu or sub-selection

3. Cursor Down / Decrease Values

Move the cursor down or decrease values.

4. Enter

Enter into sub-menu or confirm the selection.

5. Previous

Select previous file in file list.

6. Next

Select next file in file list.

7. Stop

Give up the file that is in pause mode. You can't stop file directly which is not in pause mode.

8. Run / Pause

Run the file when system is ready or in pause mode. Pause the file when it is running.

9. Move Carriage to P1

Move the carriage to the location of P1. The way to set location of P1, please see section [3.3.2](#)

10. Move Carriage to P2

Move carriage to the location of P2. The way to set location of P2, please see section [3.3.2](#)

11. Red Beam Switch / Lase

Turn on/off the red beam normally.



But if in the sub-menu of **[Alignment mode]**(See section [3.3.2](#)), this key will turn to emit the laser beam for alignment.

12. Move Carriage Left (X-)

Move the carriage left slowly when press this key shortly. If you want to move the carriage left faster, please press and hold this key.

13. Move Carriage Right (X+)

Move the carriage right slowly when press this key shortly. If you want to move the carriage right faster, please press and hold this key.

14. Move Carriage Forward (Y-)

Move the carriage forward slowly when press this key shortly. If you want to move the carriage forward faster, please press and hold this key.

15. Move Carriage Back (Y+)

Move the carriage back slowly when press this key shortly. If you want to move the carriage back faster, please press and hold this key.

16. Homing

Move the carriage to home and reset the position of home if the carriage loses position.



After the homing process, you have to press  so that you can leave the homing page.

17. Ready Indicator

This indicator will be on when system is ready to run file and no file is in pause mode.

18. Laser Indicator

This indicator will be on when laser tube is ready.

19. Door Indicator

This indicator will be on when all doors with interlocks are closed.

20. Table Up

Move the table up slowly when press this key shortly. If you want to move the table up faster, please press and hold this key.

21. Auto Focusing

Automatically adjust the distance of lens and material to focus length.

22. Table Down

Move the table down slowly when press this key shortly. If you want to move the table down faster, please press and hold this key.

3.3.2 Operating Menu

1. Work Display

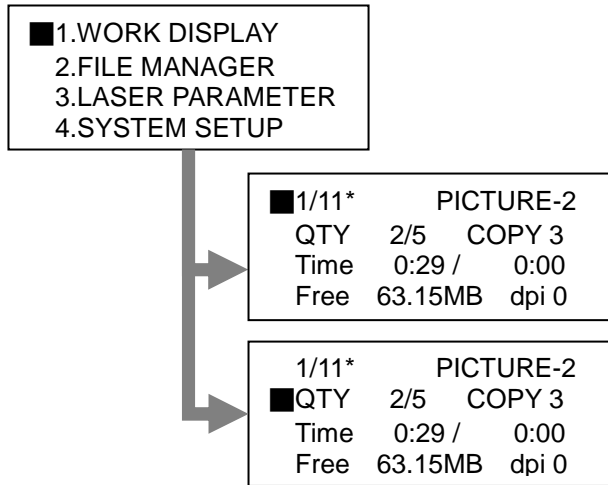

- **1 / 11***
Indicate that there are totally 11 files in memory, and the first file is selected at present. You can press and to select files.
- **PICTURE-2 :**
Indicates that the first file is named "PICTURE-2".You can name file on the tab "Page" of driver. (See section [3.4.3](#))
- **QTY 2/5 :**
Indicates that the file is limited to be executed 5 times at most, and system has finished 2 times. It will be invalid to press : system has finished 5 times. The way to modify this setting is described in section [3.4.3](#).
- **COPY 3 :**
Indicates that the file will repeat 3 times automatically if you press me. The way to modify this setting is described in section [3.4.3](#).
- **Time 0:29 / 0:00**
The first timer records the pass time at present when a file is executed. The second timer will record the total time if the file has ever finished at one time.
- **Free 63.15 MB dpi 0**
If no file is executed, this line will display available memory. If a file is being executed, it will display the current power and speed settings.

2. FILE MANAGER

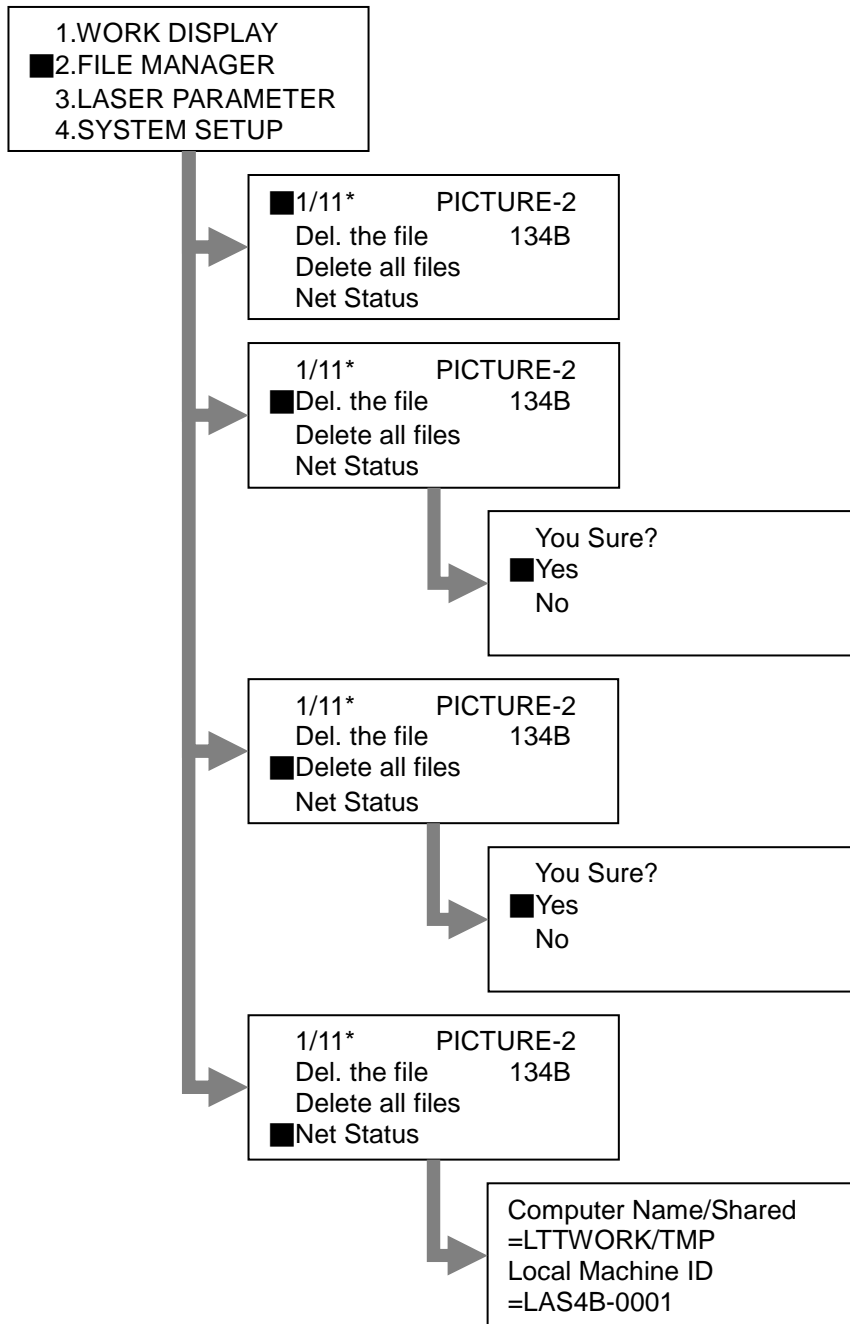

- **1 /11*PICTURE-2**
Like the definition in Work display, it indicates the number and name of files. You can press ◀ and ▶ to select files.
- **Del. the file :**
This selection can delete single file which is selected at present.
- **Delete all files :**
This selection can delete all files in memory.
- **Net Status**
This selection can show the settings of Ethernet.

3. Laser Parameter

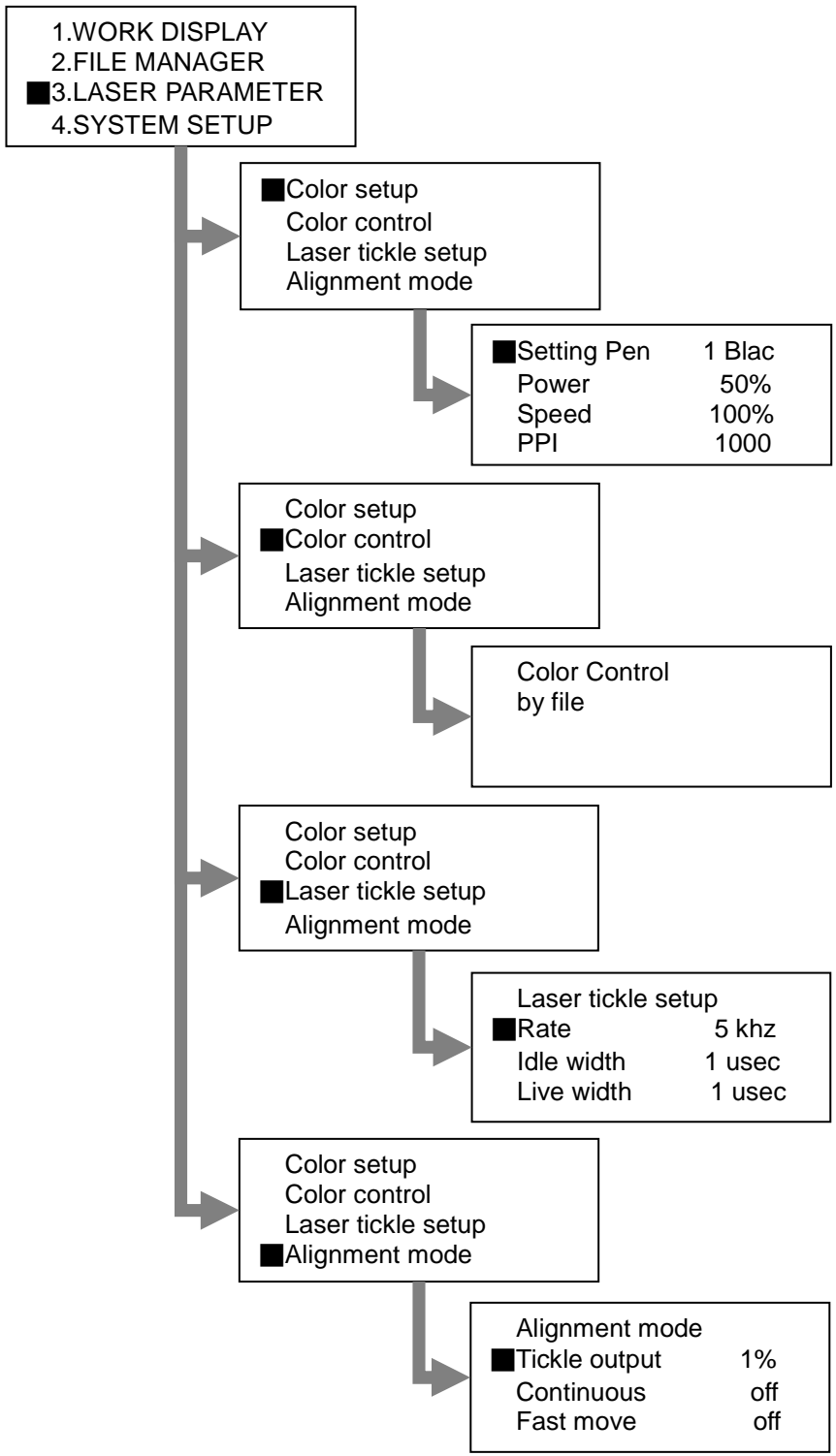

■ **Color Setup**

These settings of each color can be adjusted under this selection after the file has been sent. This is useful when testing parameters.

● **Setting Pen**

Indicates the color you want to modify.

● **Power**

Indicates the present power for setting pen. Its range is between 0~100%.

● **Speed**

Indicates the present speed for setting pen. Its range is between 0~100%.

● **PPI**

Indicates the number of pulses per inch for setting pen. It has six options, and they are 166, 200, 250, 333, 500, and 1000.

■ **Color Control**

There are two options: **[by file]** and **[by panel]**. **[by file]** means that the color settings are defined based on print driver for single file. **[by panel]** means that the color settings are defined based on **[Color Setup]** for all files.



When you check the join curve function in your files, the [by panel] will become no function even you still can adjust it.



■ **Laser Tickle Setup**

The laser tickle pre-ionizes the gas into a plasma state so that it is just below the lase threshold. Increasing tickle width beyond $1\mu s$ will add enough energy to the plasma to cause laser emission. By applying a laser tickle, the laser will respond predictably to laser signal even when there is considerable "off" time between applied pulses. It is recommended **NOT** to change the settings unless instructed to by a LTT technician.





■ **Alignment Mode**

This function is used for alignment of laser. It is recommended **NOT** to use this function unless instructed to by a LTT technician.

● **Tickle output**

Indicates the power for laser tickle. Its range is between 0~100%.

● **Continuous**

If this function is on and presst  aser tickle will emit continuously until pressing again.  his function is off, the laser tickle emit only when you keep pressing 

● **Fast move**

If this function is on, you can move the carriage faster to nine position of working table by using motion control keys.

4. System Setup

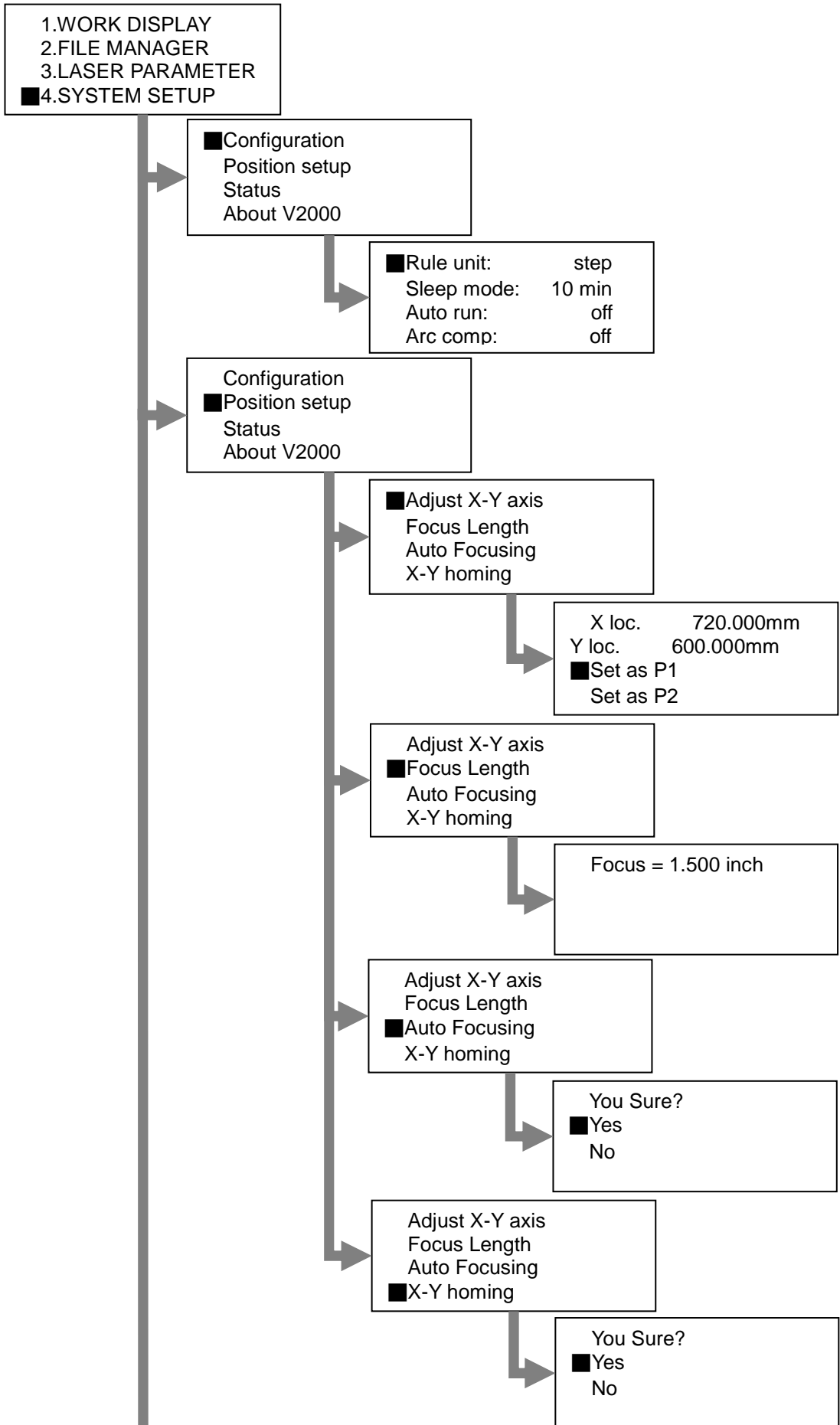

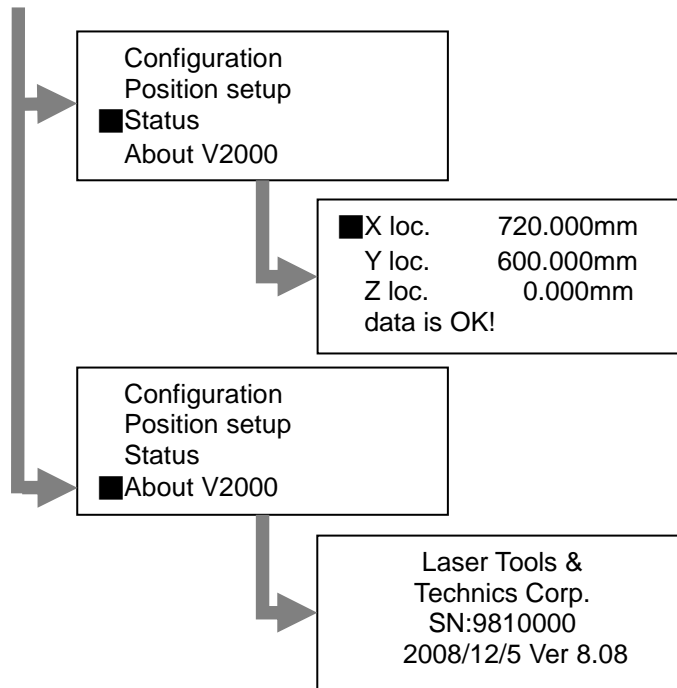

■ **Configuration**

● **Rule unit**

This function can allow user to select the unit of length for system. There are three options: **step**, **millimeter**, and **inch**.

● **Sleep mode**

After the setting the time, system will turn off the power of laser tube if there is still no file being executed.

● **Auto run**

This item has been deactivated.

● **Arc comp**

Compensates laser output power while cutting an arc.

■ **Position setup**

● **Adjust X-Y axis**

This function can allow user to set the position of **[P1]** and **[P2]**. Please move the carriage to the position that you want set for **[P1]** or **[P2]**. Then press **[Enter]** when the cursor is on the right side of **[Set as P1]** or **[Set as P2]**.

● **Focus Length**

This function can change focal length for auto focusing if you change the size of focus lens.

● **Auto Focusing**

Focusing the laser automatically. This function is the same with .

● **X-Y homing**

Move the carriage to home, and reset the position of home if the carriage loses position. This function is the same with .

- **Status**

This function can show the position of carriage and table.

- **About V2000**

This function can show the firmware version and the machine serial number.

3.4 Print Driver Operation

Because V2000 is controlled by a standard Windows printer driver, you can create the drawing on your favorite graphics software based on Windows system. When you want to send files to machine, you can easily modify the driver settings just like using a desktop printer. There are four tabs in printer driver programming: **Laser**, **Job**, **Page**, and **Power scale**.

3.4.1 Laser Tab

The **[Laser]** tab contains Power, Speed, and PPI for eight colors. Other functions enable users to save and load configuration files of driver settings, check driver information.

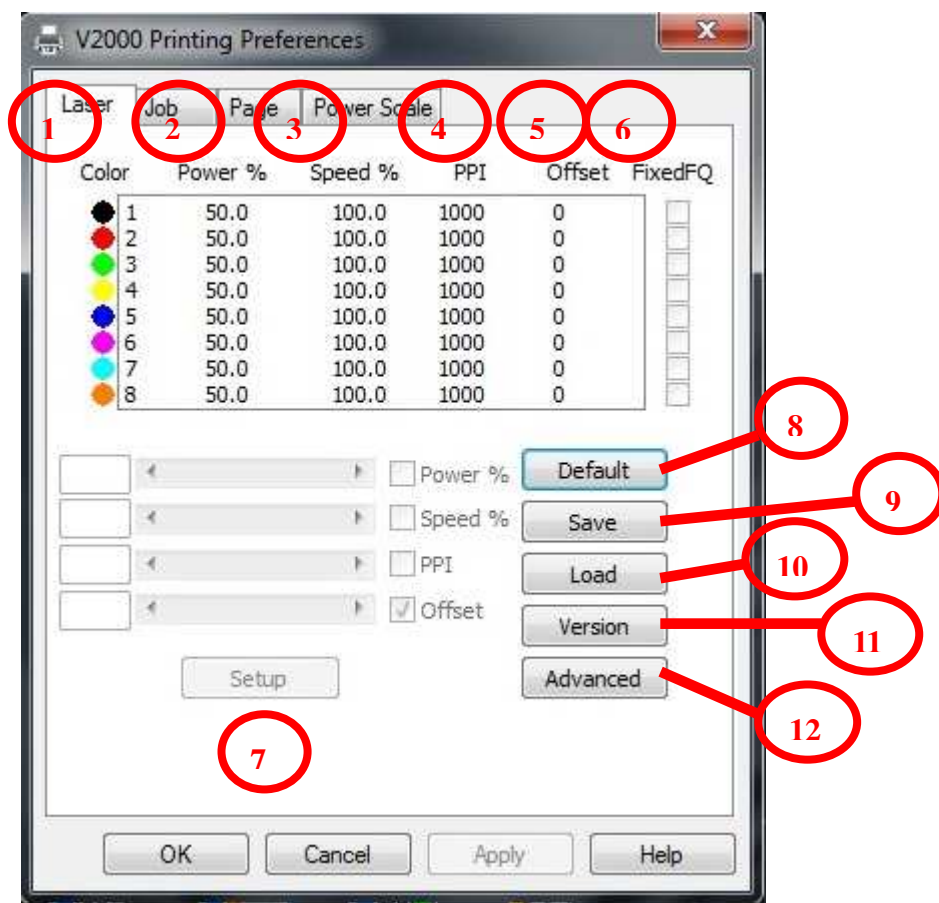

1. Color

V2000 system can cut or engrave with eight groups of power, speed and PPI according to the color in drawing. If the color in drawing does not belong any one of these eight colors, then driver will choose a similar one according to its RGB values.

2. Power

This item can control the output power by setting the percentage of maximum power. For example, if the maximum power of Laser generator is 30 Watts, then setting 50% power will generate about 15 Watts of output power.

3. Speed

This item can control the output speed by setting the percentage of maximum speed. For example, if the maximum speed of engraving is 60ips, then setting 50% speed will produce about 30ips of engraving speed.

4. PPI

PPI means "Pulses Per Inch". This item controls the numbers of laser pulses in one inch. This item only affects vector cutting. It is recommended to decrease PPI for dull materials like wood and increased for polished materials like acrylic.

5. Offset

The function is only for a closed vector path like circles and polygons. It can output an offset value to the original drawing.

The positive value will make the drawing bigger and the negative will make it smaller. The unit is 1um.

6. Fix FQ

Normally, to balance the laser output between high speed and slow speed area, the controller will automatically adjust the laser power according to motion speed. Check this option will disable the adjustment and fix the laser output frequency to maintain the laser power ratio.

*This function is only available on some model.

7. Setup

The settings of power, speed, and PPI can be modified by editing the text boxes and dragging the sliders. Then please click the setup button to save the new values for each setting.

Default

8. Save

Clicking this button will pop up a [Save Setup File] window. User can save all settings into a configuration file (*.lcf).

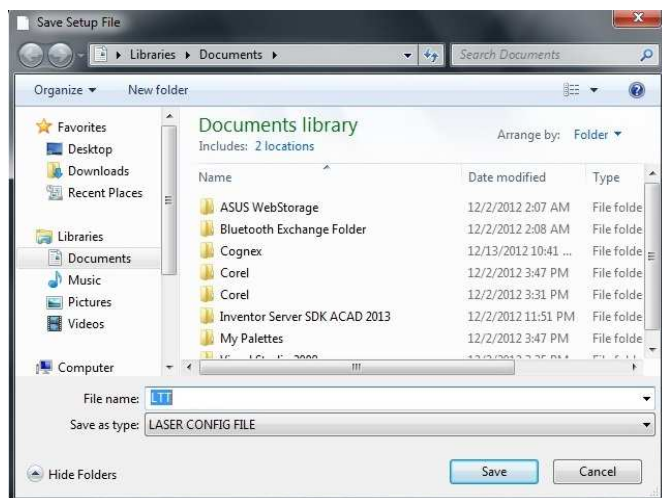

9. Load

Clicking this button will pop up a **[Load Setup File]** window. User can load all settings from a configuration file (*.lcf).

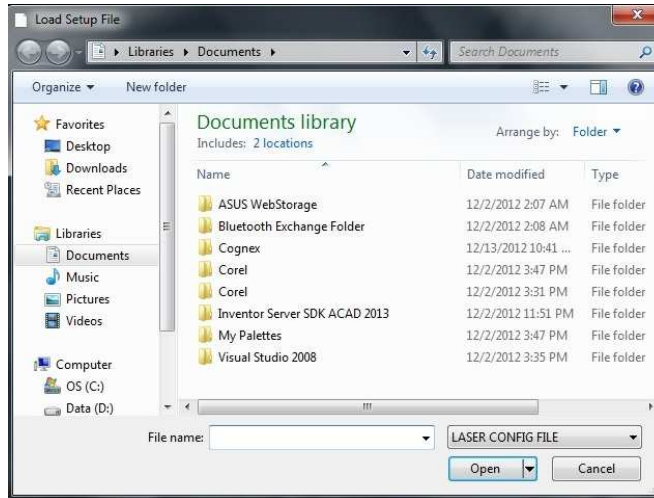

10. Version

Clicking this button will show the version of driver.



12. Advanced

Clicking this button will pop up a **[Advanced]** window that is protected by password. If you need password to modify these settings, please connect LTT. It is recommended **NOT** to change the settings unless instructed to by a LTT technician.

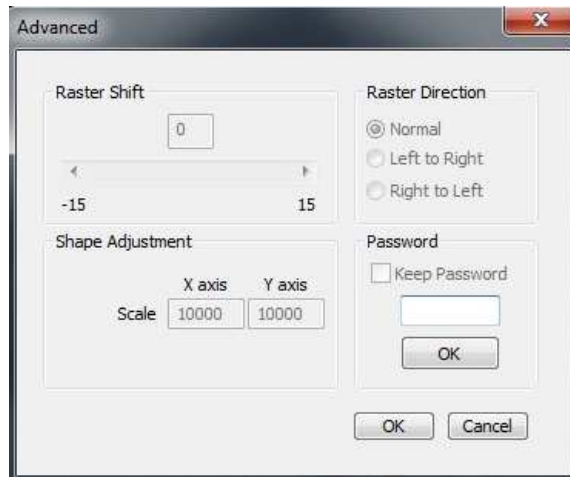

Raster Shift

***This function only works for servo motor machine model.**

Shape Adjustment

The range of is from 9500 to 10500. The default setting 10000 means the vector scales remain the original size without any scaling. When X axis's scale sets 10500, it means output will be multiplied by 1.05 times in x axis's direction. If the value is out of the setting range, it will turn into the originally setting value: X axis=10000, Y axis=10000 automatically. The Shape Adjustment is only works with vector (cutting) drawings.

Raster Direction

You can choose a raster quality by changing the Raster Direction. If you choose Normal, the laser opens both on direction of left to right and right to left. Otherwise, if you choose Left to Right or Right to Left, the laser opens only on the single direction you choose. All of those three options will produce correct engraving result as you set, but the quality of single direction will be better then the Normal option.

Password

Check the **[Keep Password]** box, then click the **[OK]** button to allow for keeping the password. Next time you can modify the settings without password.

3.4.2 Job Tab

The Job tabs divided into four sections: **Job Mode**, **Resolution**, **Engrave Type**, and **Cut & Engrave Setup**.

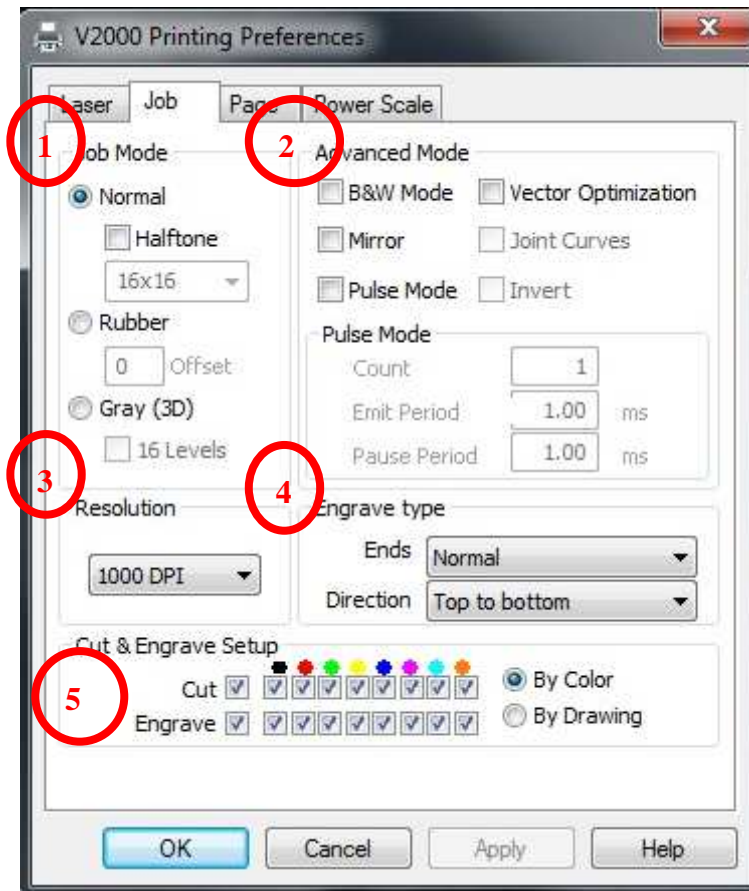

1. Job Mode

Normal

This mode uses the eight color settings to raster engrave and vector cut graphics drawn in the graphic software. You can use the **Halftone** function if you want to simulate the Bitmap image through the use of equally spaced dots of different size. The bitmap image will be filled with different dot/grid density from 16x16 dots to 4x4 dots. 16x16 dithering type would present the image higher resolution than the 4x4 dithering.

Rubber

This mode is used for making rubber stamps. This mode causes the laser to create a tapered profile on the edge of the engraving. This gives small graphics more strength, preventing them from folding over when used. The profile of the edge depends on the power settings on the Power Scale tab. You can create custom profiles, but the default generally works well. You may notice that the Offset input box becomes available when the Rubber mode is selected. The Offset function will automatically increase the boldness of the engraving. The primary benefit of the offset feature is the improved quality of small text.

Gray(3D)

This mode is used for engraving three-dimensional images. The driver uses 256 shades of gray to vary the amount of laser power. Darker colors of gray engrave at higher powers and lighter shades engrave at lower powers. If the 16 Levels option is enabled, the driver converts the image into 16 shades of gray and the Power Scale tab is used to control the power used for each shade of gray.

2. Advanced Mode

B&W mode

This option converts all raster objects' colors to black and white and uses the black laser setting for engraving. This mode still uses eight color settings to cut vector objects.

Mirror

This mode will mirror the images horizontally for reverse engraving. This is useful when engraving on the backs of transparent materials such as acrylic. However, we suggest mirroring your images in the graphics program which will allow you to accurately preview the engraving before the job is sent to the engraver.

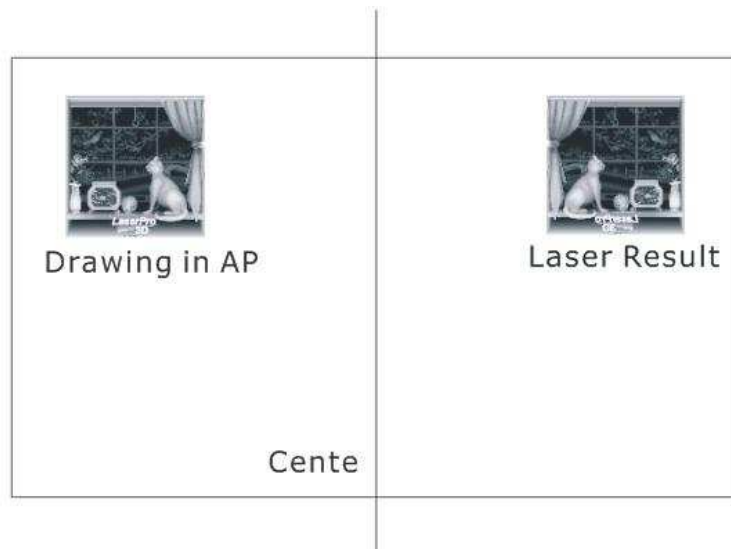

Pulse Mode

This mode can be enabled for drilling holes. For details on holes drilling, contact technical support.

Vector Optimization

This mode can modify the working path based on positions of vector in the drawing, it can decrease working time.

Joint Curves

Checking this box will make cutting circle or arc faster and smoother.

3. Resolution

The only variable in the resolution section is DPI otherwise known as dots per inch. The DPI setting controls the dot density of the engraver when raster engraving. This setting affects the resolution along the X and Y axis. Higher DPI settings result in smoother edges but also require more time to engrave

4. Engrave type

Ends

The Ends dropdown box allows for two selections. The Normal setting provides the fastest engraving but the edges of detailed graphics may not align properly. The Fine setting results in slower engraving but detailed images are engraved flawlessly.

Direction

The Direction options are Top to Bottom and Bottom to Top. These options determine if the engraver begins raster engraving at the top or the bottom of the graphic. When using the bottom to top setting engraving results are slightly cleaner due to the direction of airflow inside the engraver.

5. Cut & Engrave Setup

The Cut & Engrave Setup section allows the user to enable and disable certain functions of the engraver. If the box next to Cut is unchecked the engraver will disregard any portions of the graphics that instruct the laser to vector cut. Likewise, if the box next to Engrave is unchecked the engraver will disregard the portions of the graphic that would normally be raster engraved. For more precise control the boxes below each color allow the user to disable the cut or engrave options independently for each color.

By Color

When **[By Color]** is selected vector are cut according to the predefined color order. And vectors of the same color are cut in the sequence they have been drawn. Engraving objects' orders are according to color only. Raster lines of the same color are engraving by **[Direction]** setting

By Drawing

When **[By Drawing]** is selected all vectors are cut in the sequence in which they have been drawn, regardless of color. Engraving objects won't follow this.

3.4.3 Page Tab

The Page Tab is divided into four sections: **Page Setup**, **Job Title**, **Repetition**, and **Material**.

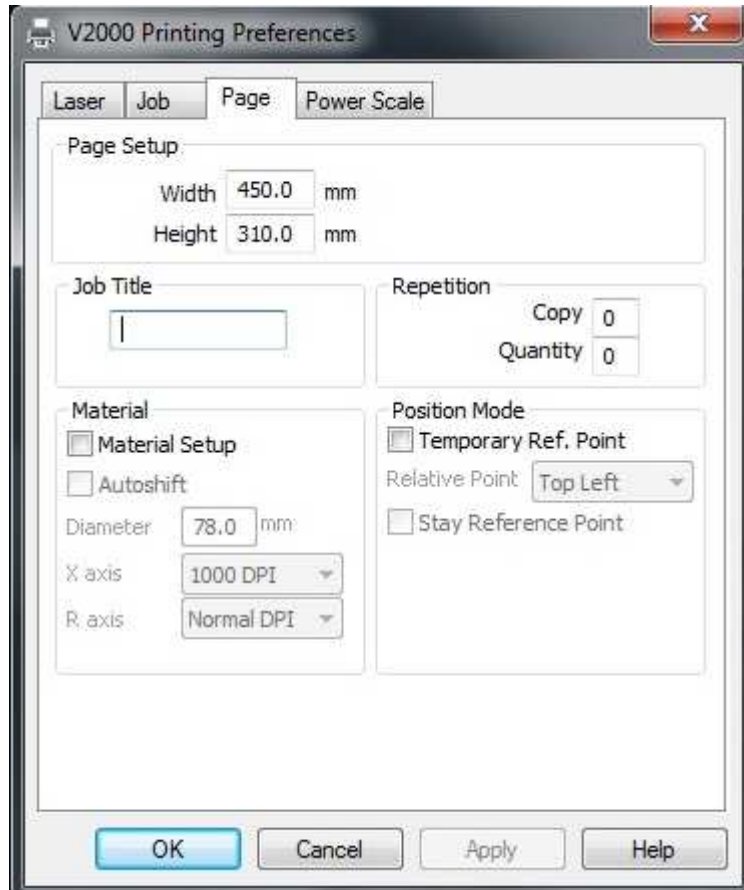

1. Page Setup

The Page Setup section includes the Width and Height information of machine. There are three functions in this section. They are **Imperial**, **Joint Curves**, and **Time Estimate**.

2. Job Title

The Job Title input box allows the user to input a title for the job being sent to the engraver. The title entered will be the top line of the job file on the display of the engraver.

3. Repetition

The Repetition section allows the user to modify the setting of **[Copy]** and **[Quantity]** which will be shown on panel. (See section [3.2.2](#))

4. Material

The Material section is used for setting up the driver for the rotary attachment. When the Material setup checkbox is checked the Material section is enabled. The Diameter input box allows you to enter the diameter of the object in the rotary attachment. When checked, the **[Autoshift]** check box causes the driver to ignore the vertical position of the graphic on the page. This causes the engraver to begin engraving without initially rotating the object. This feature allows for easier alignment of graphics on items with handles. The X axis dropdown box is used for setting the DPI when the rotary attachment is in use. The R axis dropdown box options no longer affect the functions of the engraver.

5. Position Mode

Temp Ref. Point

If this box is checked, the file will not execute in the position as application software. Otherwise, it will execute in the position where user determine on machine.

Relative Point

There are nine relative points. They are **Top Left, Top Middle, Top Right, Middle Left, Center, MiddleRight, Bottom Left, Bottom Middle** and **BottomRight**. Those points mean different positions on the boundary of drawing in application software.

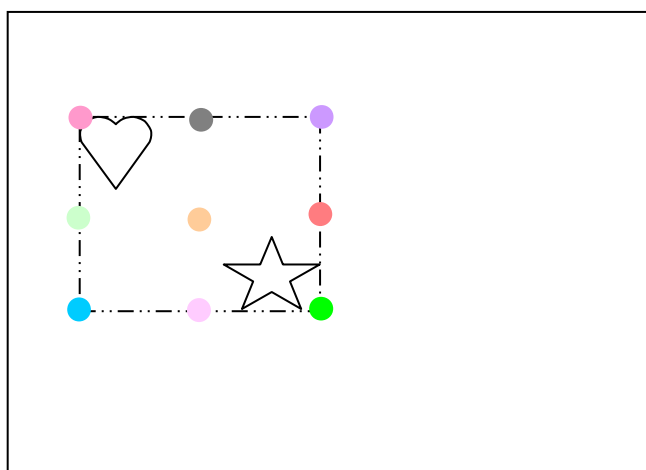

- **Top Left**
- **Top Middle**
- **Top Right**
- **Middle Left**
- **Center**
- **MiddleRight**
- **Bottom Left**
- **Bottom Middle**
- **BottomRight**
- ♡ ☆ **Pattern**
- **Boundary**

Stay Reference Point

If you want to stay on reference point after job finished, you can choose this option. This option can save your time when you want to use.

3.4.4 Power Scale

The Power Scale tab is divided into two sections, **Power Scale** and **Custom Power Scale**.

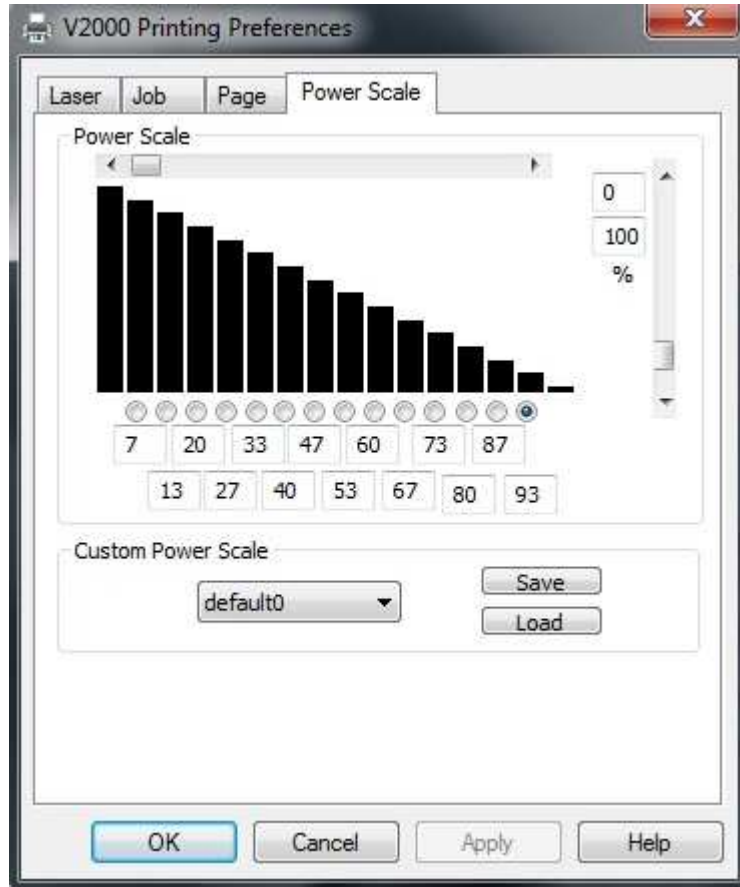

1. Power Scale

The Power Scale section is used to adjust the strength of the laser power. While in Rubber mode, the Power Scale function will control the curve of the tapered profile. While in Gray (3D) mode, with 16 Levels option selected, the Power Scale function will control the amount of laser power for each gray level. The horizontal scrollbar is used to adjust the default power scale setting. The vertical scrollbar and the input boxes below the bar graph are used to independently adjust each power scale depending on which scale is selected.

2. Custom Power Scale

The Custom Power Scale section allows the user to Save and Load up to five Power Scale parameters for later use.

3.5 LTT Product Tools

3.5.1 System Upgrade

Generally, the file for upgrade will be provided from LTT. The file type is **[*.ice]**. While upgrade is processing and the power is turned off or the cable is disconnected, the V2000 may not be upgraded for the moment. If this situation happens, please contact LTT.

1. Turn off the V2000, and check that the V2000 is connected with PC through USB cable.
2. Turn on the V2000 and computer. Press and hold  on the control panel right after turning on V2000 until the following screen appears.

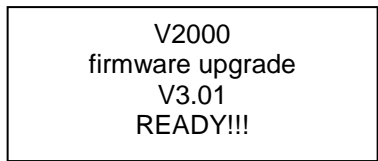

3. Run **[LTT Product Tools]**, and select the printer. **V2000**

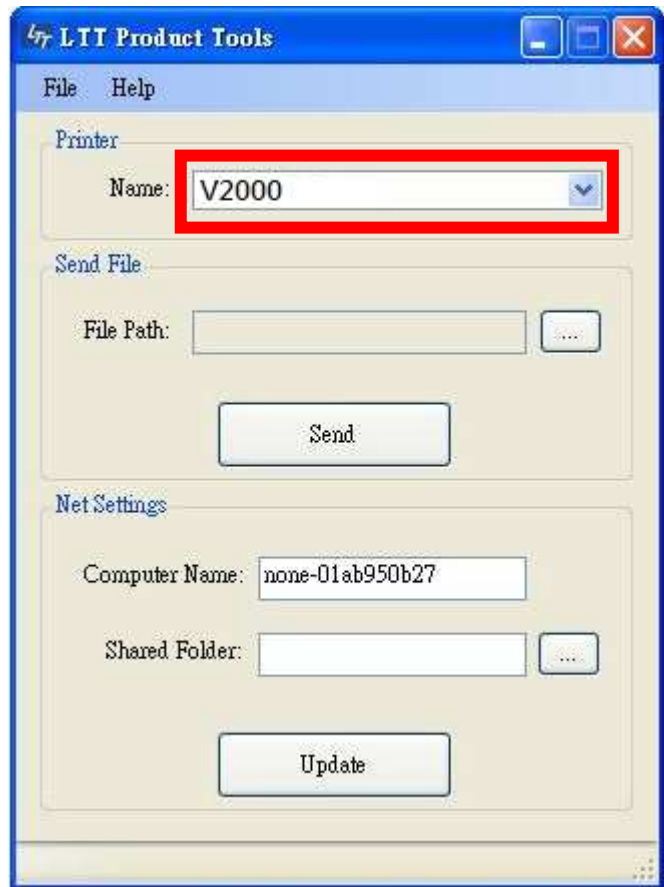

Chapter 3 Operation

4. Then select the [***.ice**] file with [...] key, then press [**Send**] key to upgrade the firmware of V2000.

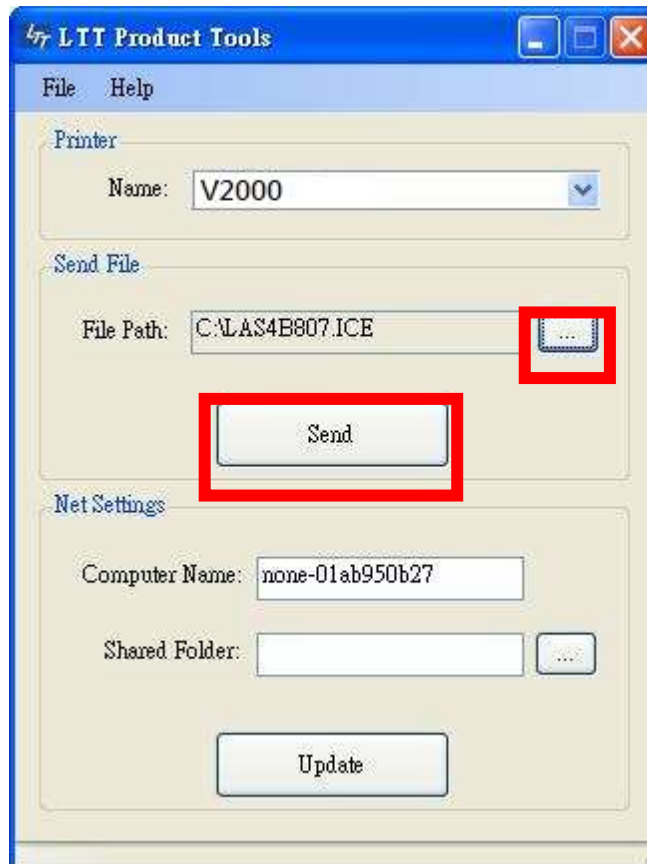

5. You will hear two short beeps along with the following display, showing that the upgrade has completed successfully.

firmware upgrade
complete !

6. Press  on the Control Panel and you will hear a beep after which V2000 returns to main menu.
7. Check the firmware version in the 4th line of the [**ABOUT**] submenu (See section [3.3.2](#)).

Chapter 4 Maintenance

4.1 Cleaning



1. Preparation

- Ensure that the system is turned off and the AC power cable is unplugged.
- Prepare for cotton swab, cotton cloth, and alcohol.

2. Clean machine

- Remove all loose dirt and debris from inside of the machine.
- Clean the top window with cotton cloth and alcohol.
- Clean the working table surface with cotton cloth and alcohol.
- Clean all of the rails of the motion system with cotton swab and alcohol.

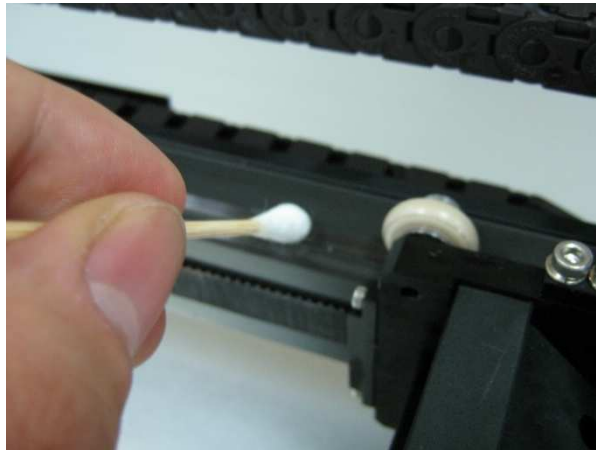

3. Clean lens and mirror

- Clean the window lens with cotton swab and alcohol.



- **Clean 2nd mirror with cotton swab and alcohol.**



- **Clean 3rd mirror and focal lens with cotton swab and alcohol.**



Clean focus lens with cotton swab and alcohol.

Pull out the focus lens.



Assembly the focus lens back after the clean process.

Chapter 5 Trouble Shooting

This chapter provides suggestions to check and solve some common problem. If you can't find any answer in this chapter, please see introduction to call technical support!!

Problem	Cause	Remedy and reference
Power is not turned on.	AC power cable is not connected properly.	Check Hardware Installation. (See section 2.4.)
	Emergency stop is pressed down.	Turn right the pushbutton. (See section 2.3.)
Laser beam is not emitted.	Laser on/off switch may be turned off.	Turn on the switch. (See section 2.3.)
	Doors with interlocks are not closed. (If "Door" indicator is dark.)	Close all doors with interlocks. (See section 2.3.)
	The temperature of laser generator is too high.	Stop job for a certain time to cool laser generator.
	Laser beam is misalignment.	Realign by adjusting mirrors.
	The setting of laser power is too low.	Increase the setting. (See section 3.4.2.)
	Laser tube is breakdown.	Please contact LTT. (See Introduction)
Cutting or engraving quality is bad.	Focal length is not suitable.	Adjust focal length. (See section 3.3.1)
	Lens and mirrors are dirty.	Clean the lens and mirrors. (See section 4.1 and 4.2)
	Setting of focal length on panel does not match with lens.	Modify the setting. (See section 3.3.2)
	Lens and mirrors are broken.	Please contact LTT. (See Introduction)
	The settings of laser power are not suitable.	Modify the setting. (See section 3.4)

Appendices

Appendix 1 Specifications

This section describes the specification of the V2000 series.

Model	2000 series
Working area	700 (L) × 500 (W) mm
Table Movement	230 (H) mm
Max. speed	1524mm/sec (60"/sec)
Resolution(DPI)	1000, 500, 333, 250, 200, 160
Memory Buffer	64MB
Interface	USB port
Laser generator	30W(air-cooled CO2 laser)
Power supply	30W : 100~240V AC, 10 Amp, 50/60 Hz
Exhaust	requiring at least 6.0 m ³ /min air flow for two 4" connection
Regulatory Compliance	CE certification RoHS directive
Standard	AutoFocus Red-beam Pointer
Options	Blower Air compressor Rotary attachment Honeycomb cutting table Rubber stamp fixture Ethernet Port

Appendix 2 Dimensions

This section describes the dimensions of V2000 series.

■ V2000 series

Unit:mm

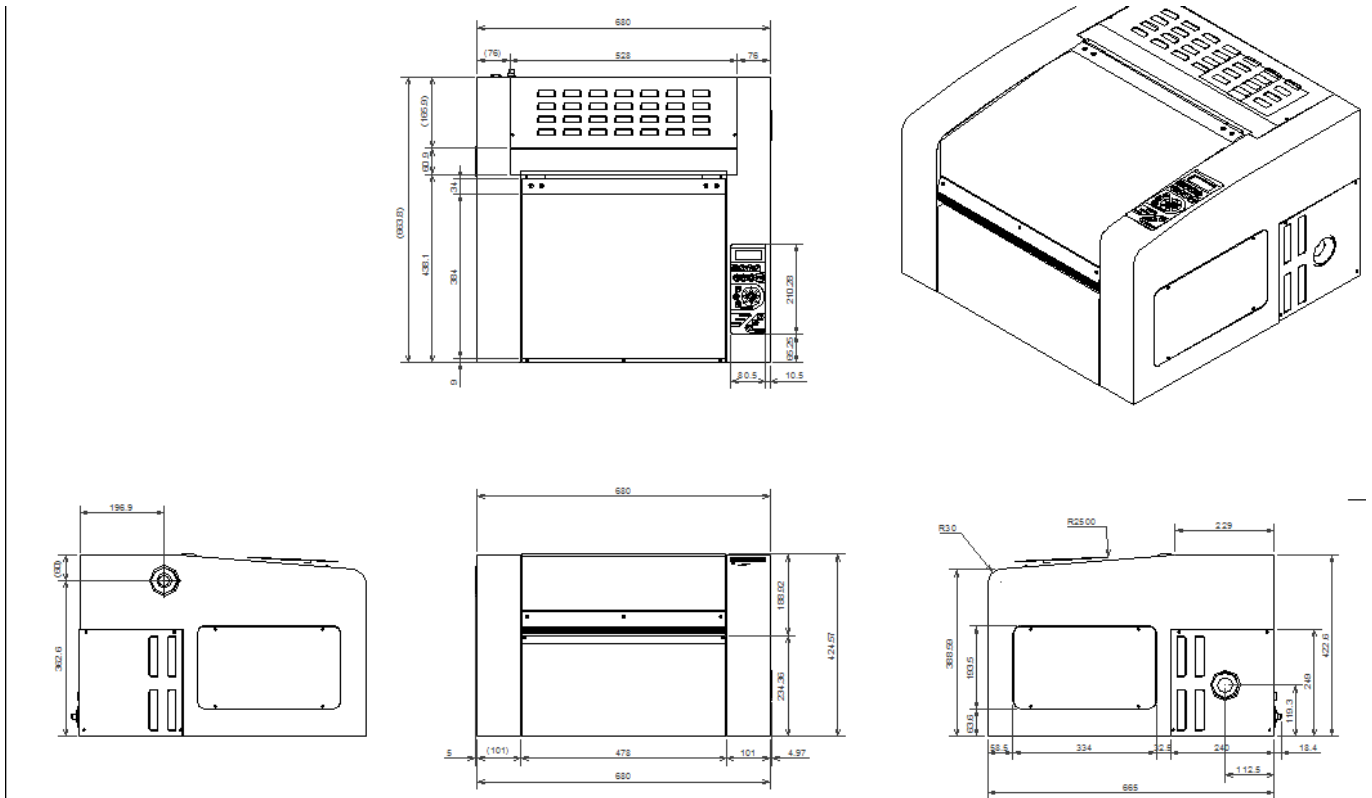

Appendix 3 Suggested Power and Speed Settings

The below settings are only intended to be starting points. Many variables can affect actual settings. Different manufacturers have different formulations, laser tubes differ in actual power output, natural materials vary greatly, and the user desired results will drastically affect actual settings.

Laser Source : 30 Watt						
Material	Type	Thickness	Speed	Power	PPI	DPI
Acrylic	Engraving		100%	20%		500/1000
	Cutting	3 mm	3%	100%	1000	
		5 mm	2%	100%	1000	
		10 mm	0.5%	100%	1000	
Anodized Aluminum	Engraving		100%	40%		500/1000
Card Stock	Cutting		40%	100%	250	
Cermark	Engraving		25%	100%		500
Ceramic Tile	Engraving		60%	100%		500
Coated Brass	Engraving		100%	50%		1000
Crystal	Engraving		100%	30%		500
Denim	Engraving		100%	30%		500
	Cutting		20%	100%	500	
Glass	Engraving		100%	50%		500
Granite	Engraving		60%	40%		333
Laser Foil	Cutting		50%	100%		1000
Laserable Plastic	Engraving		100%	20%		1000
	Cutting	1.5 mm	8%	100%	500	
Leather	Engraving		100%	70%		500
	Cutting		2%	100%		
Marble	Engraving		60%	23%		333
Rubber Stamp	Engraving		15%	100%		1000
	Cutting		4%	100%	500	
Wood	Engraving		100%	100%		500/1000
	Cutting	3 mm	7%	100%	500	
		6 mm	2.5%	100%	500	